

---

# **DEWALT**

---

[www.DEWALT.eu](http://www.DEWALT.eu)

**D27105**  
**D27105V**



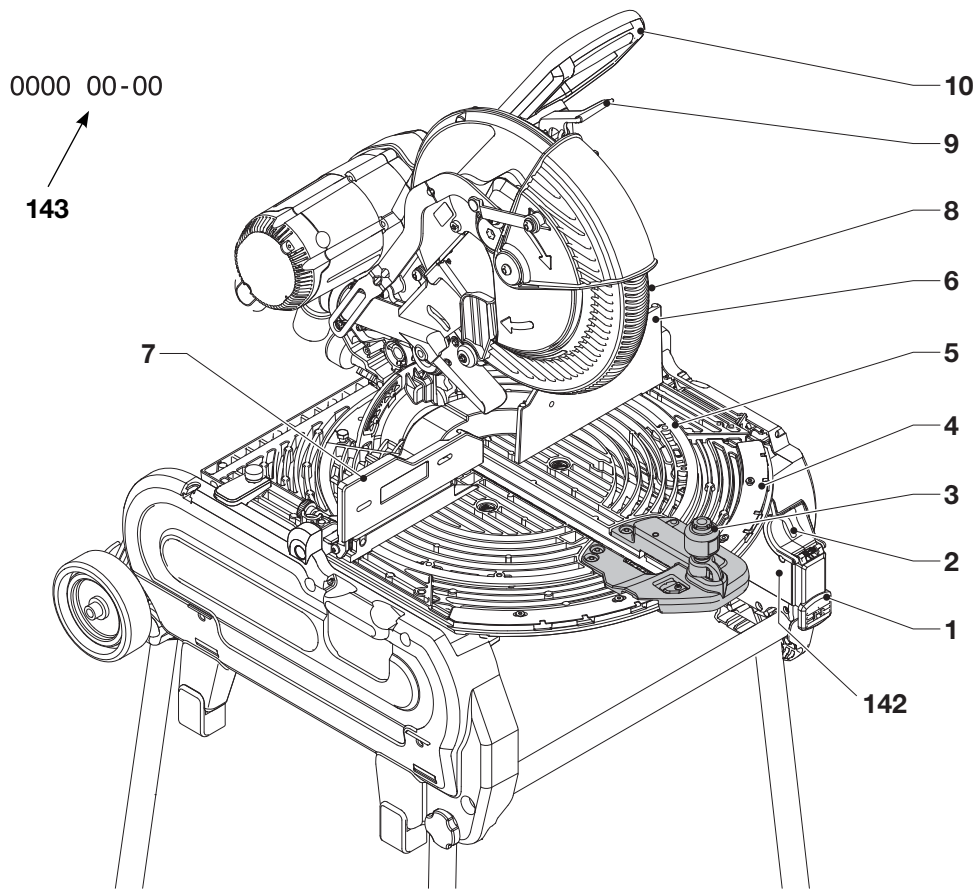

**A1**

---

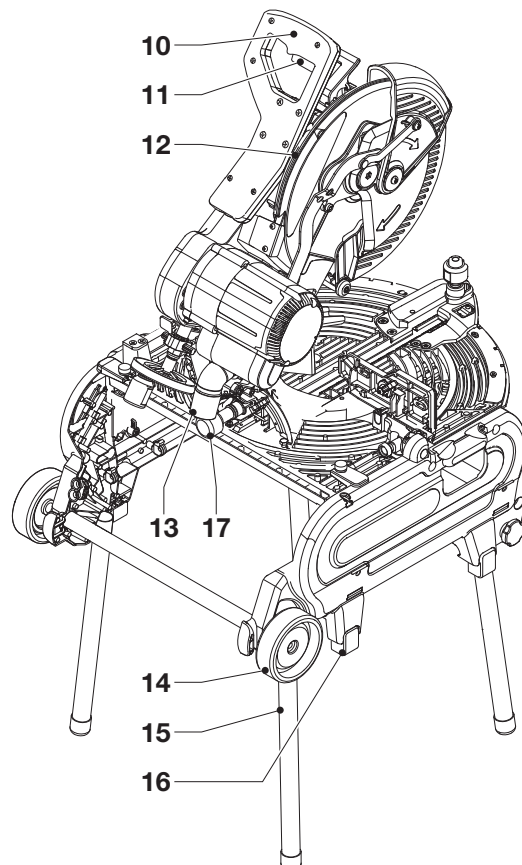

**A2**

---

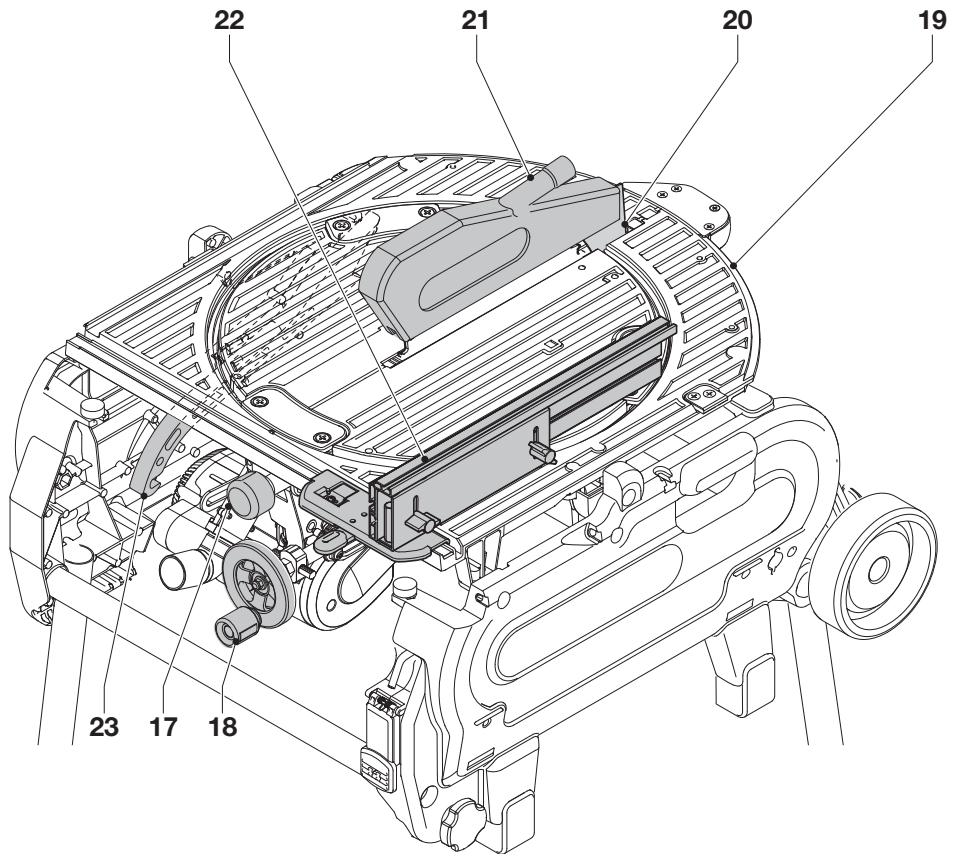

**A3**

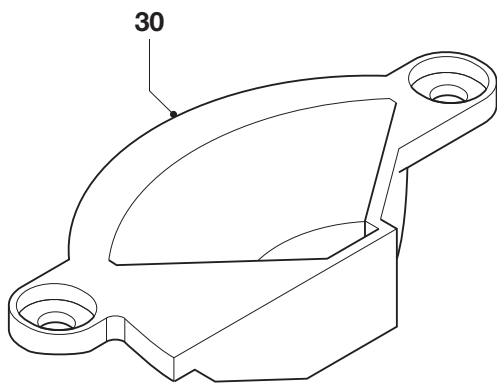

**A4**

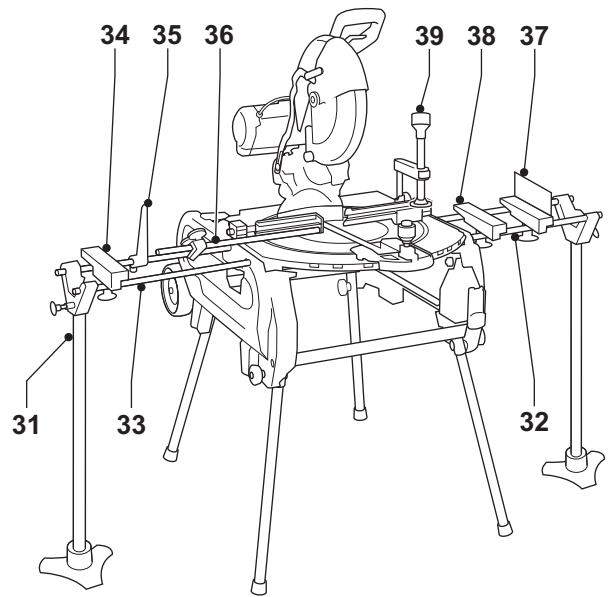

**A5**

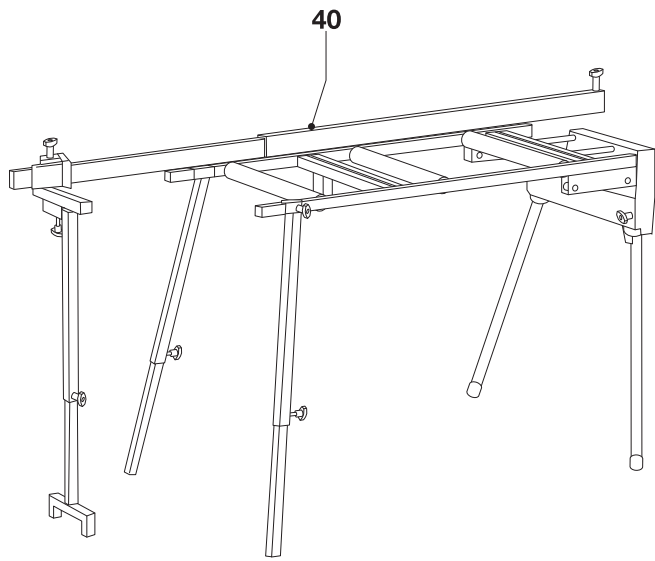

**A6**

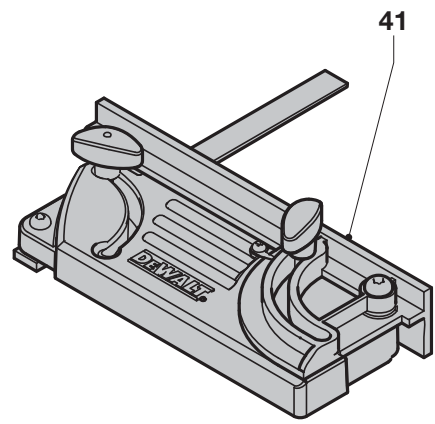

**A7**

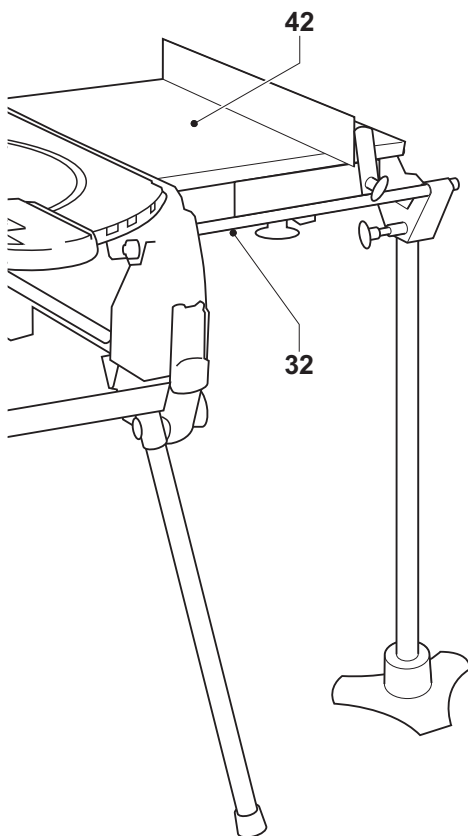

**A8**

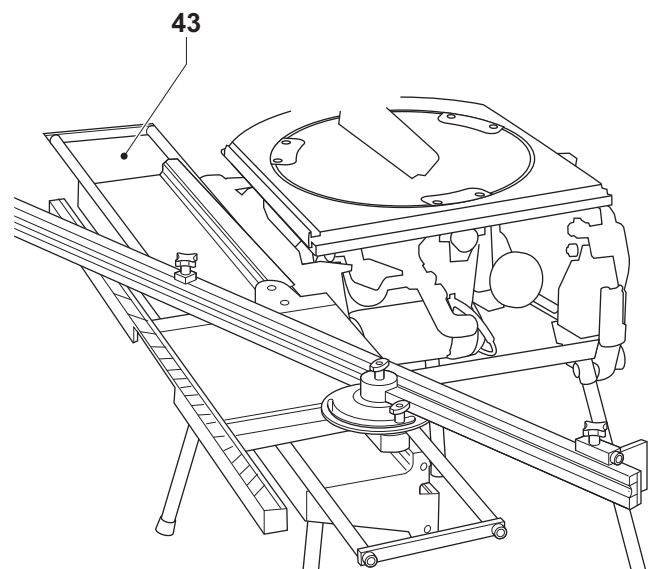

**A9**

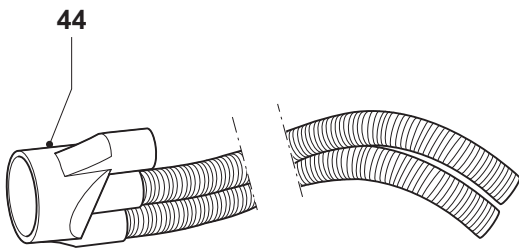

**A10**

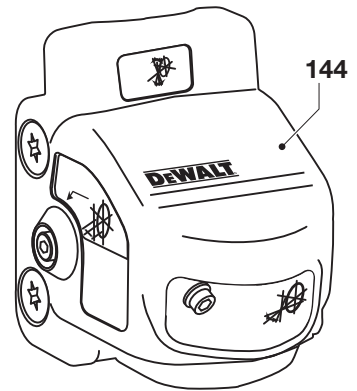

**A11**

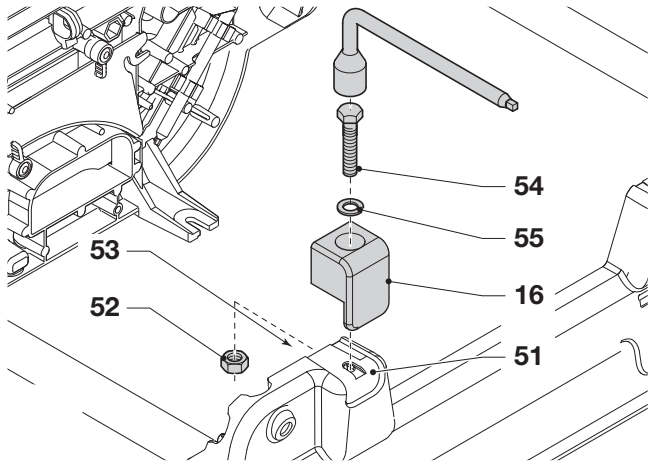

**B**

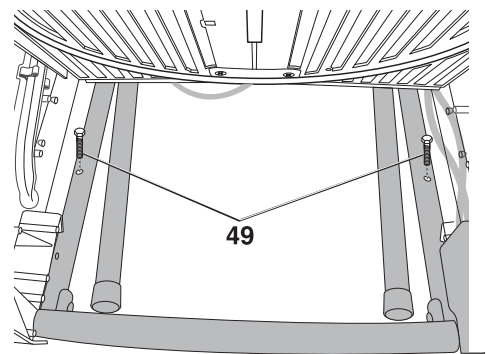

**B1**

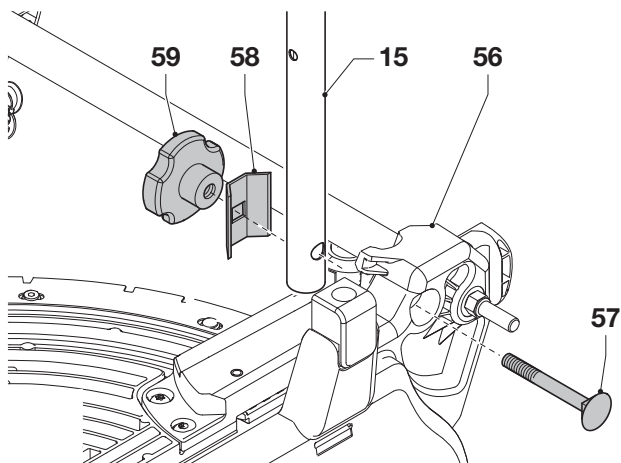

**C1**

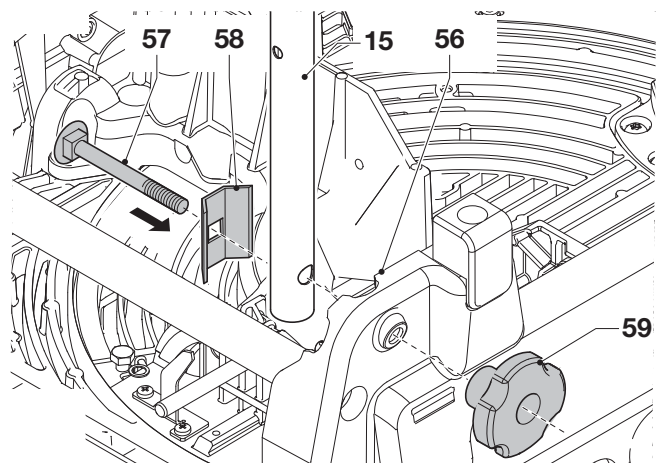

**C2**

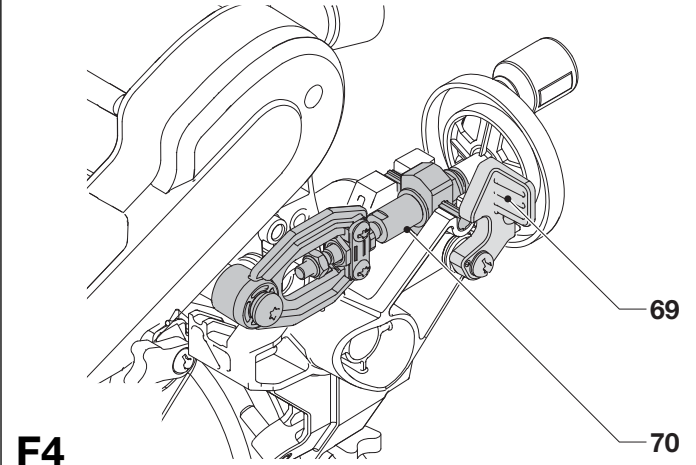
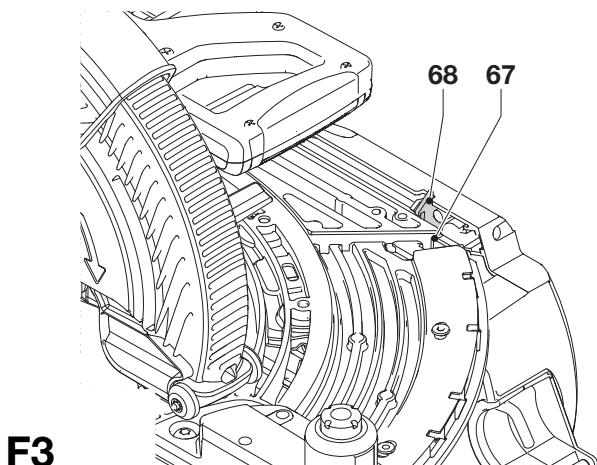
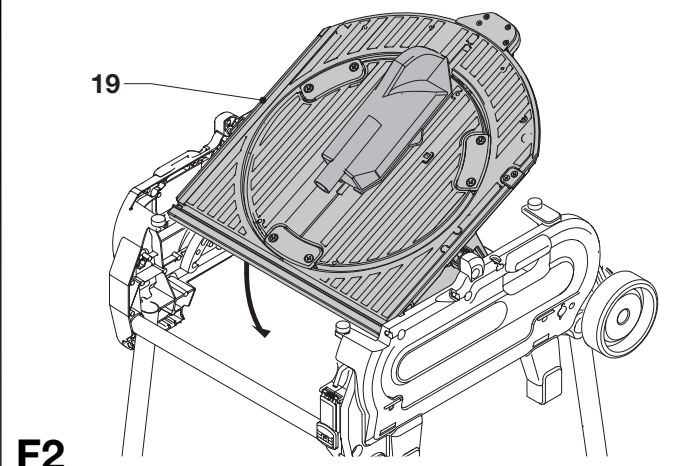
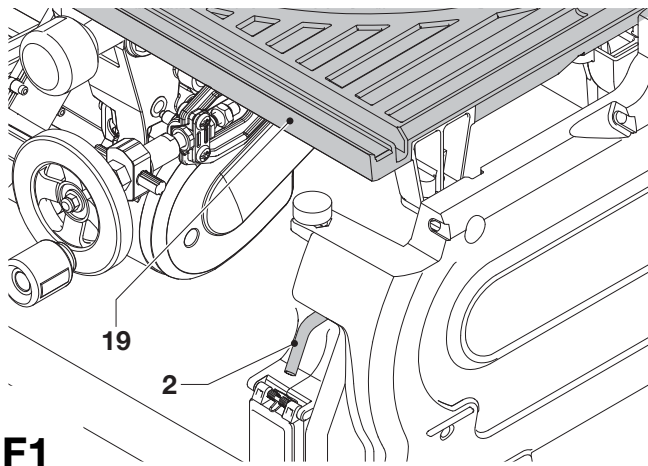
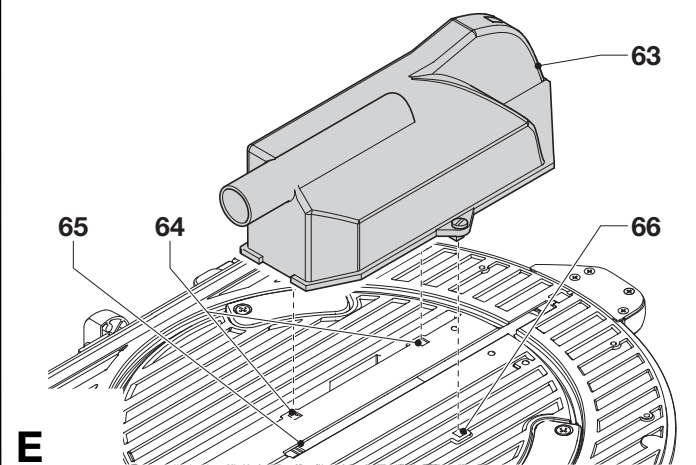
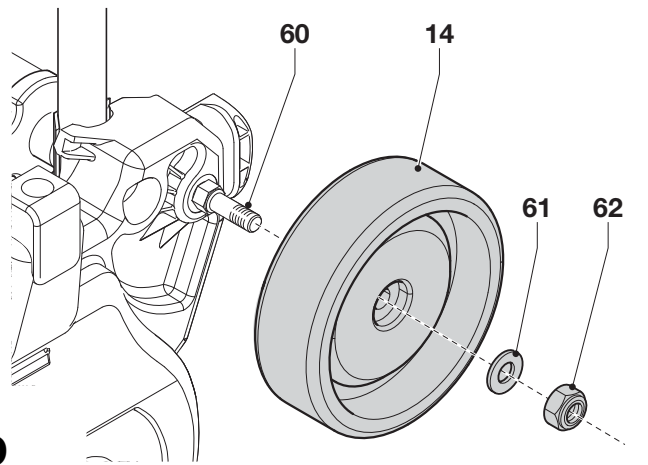
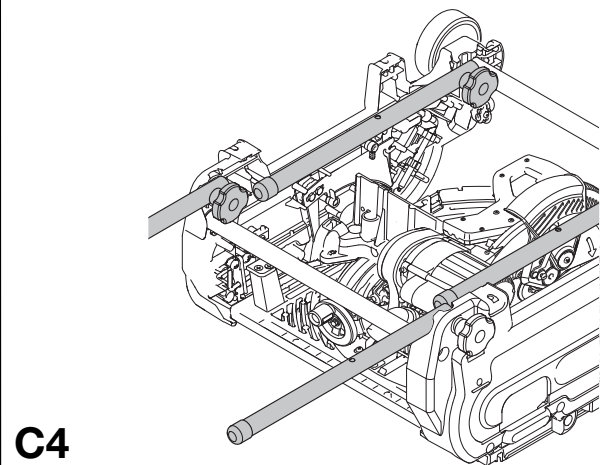
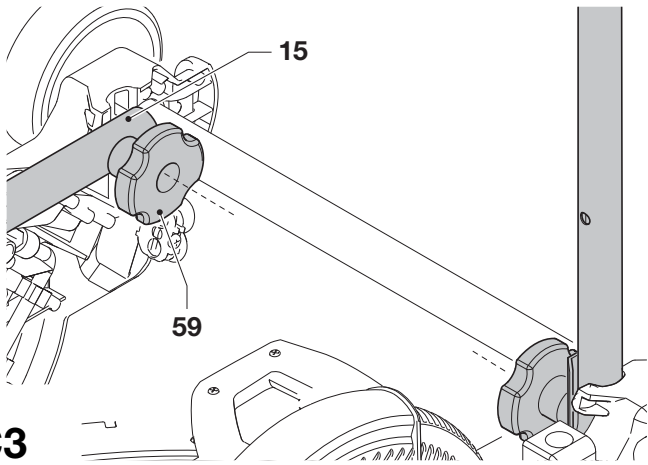

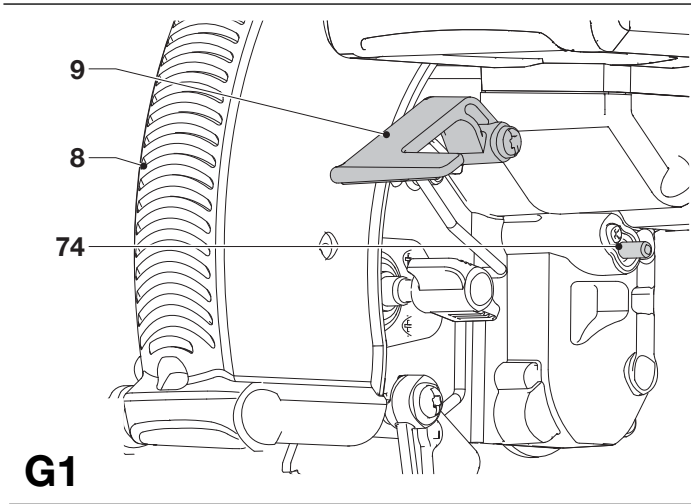

**G1**

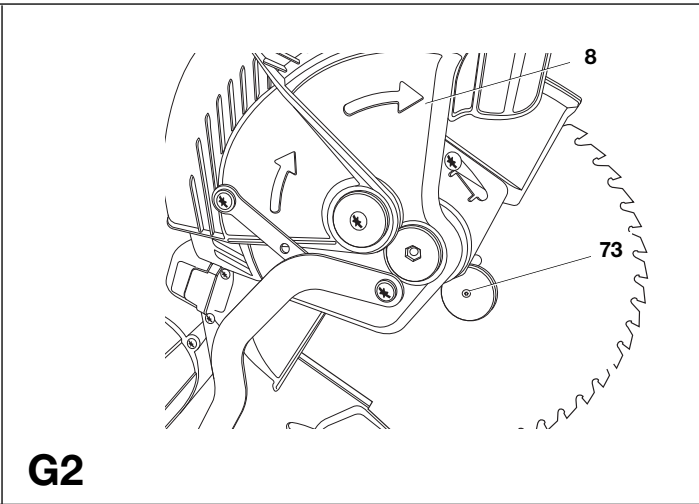

**G2**

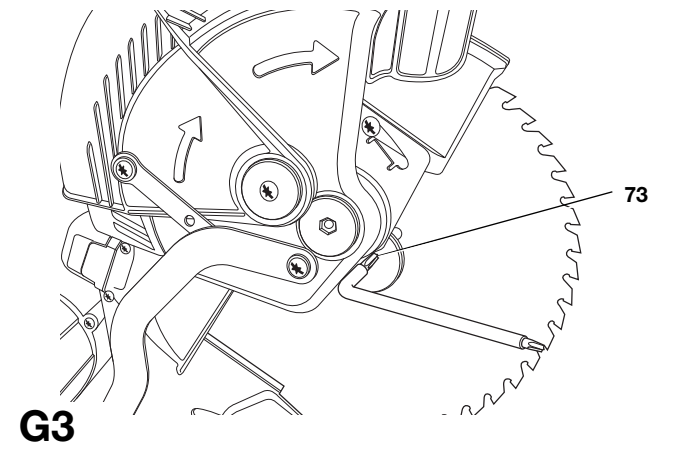

**G3**

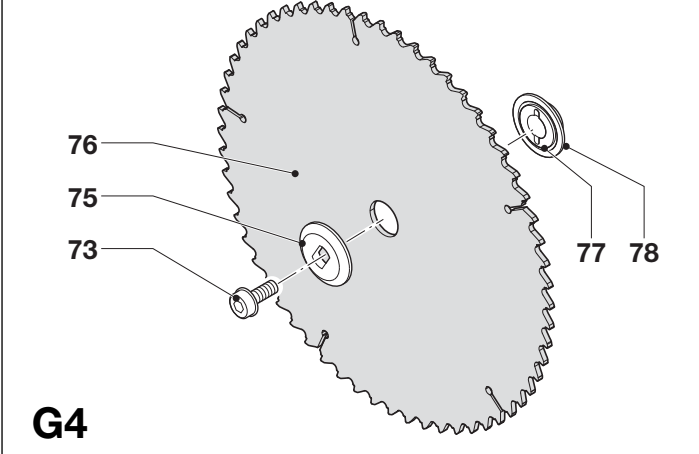

**G4**

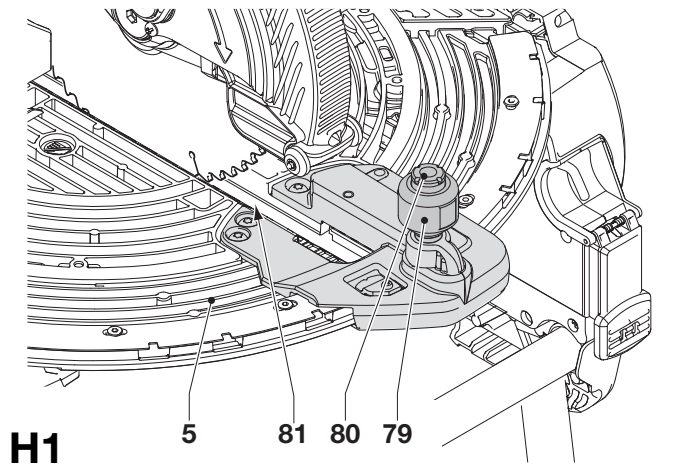

**H1**

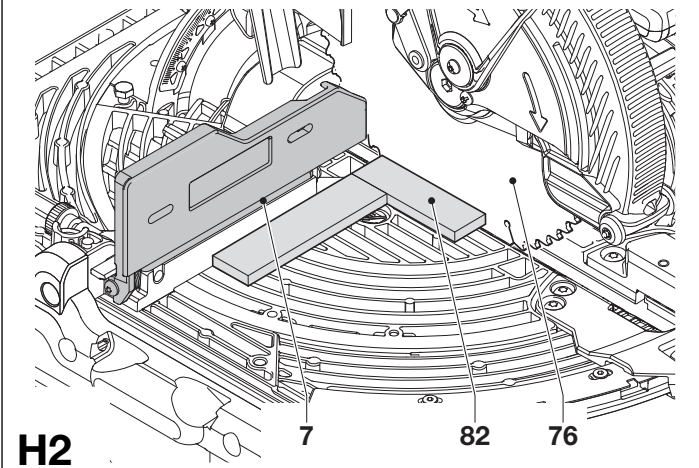

**H2**

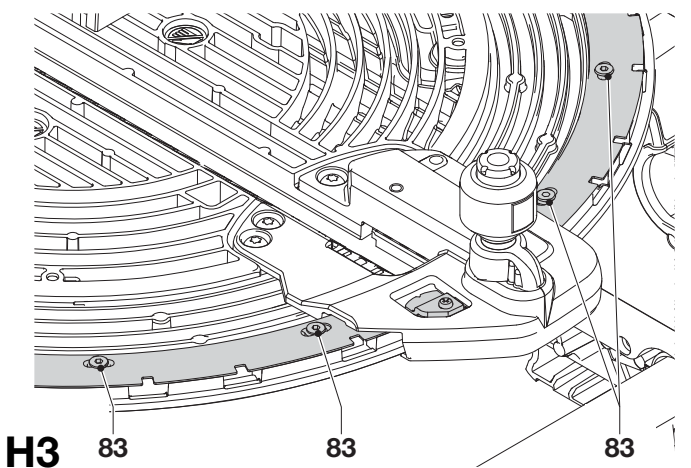

**H3**

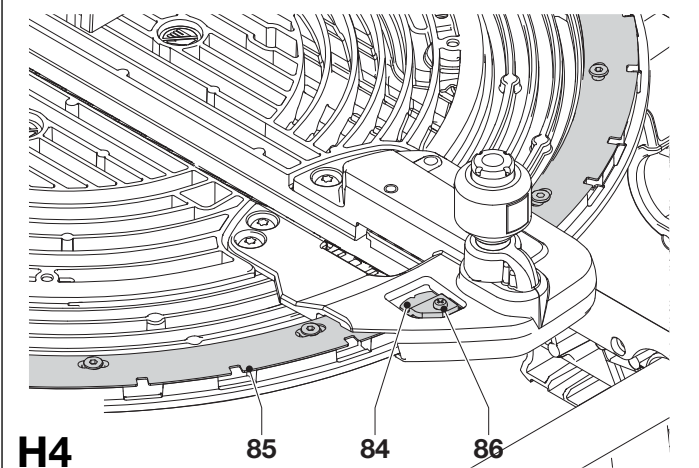

**H4**



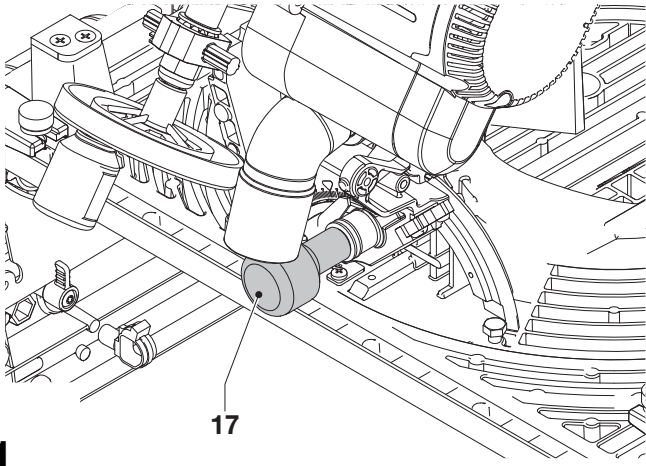

I1

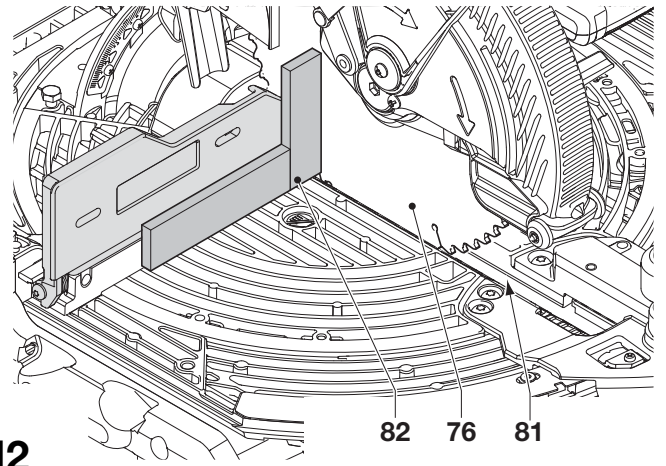

I2

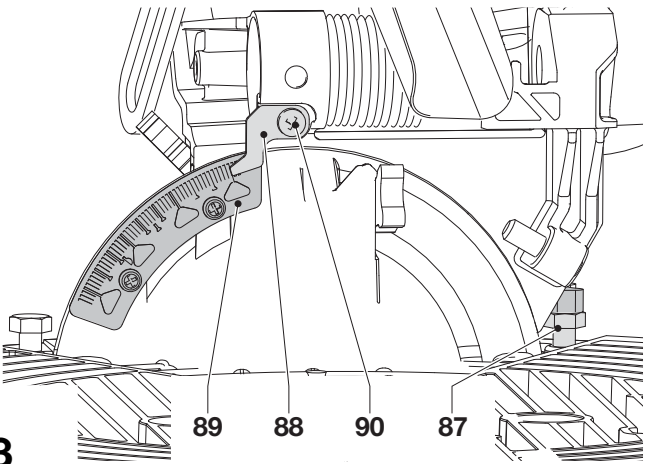

I3

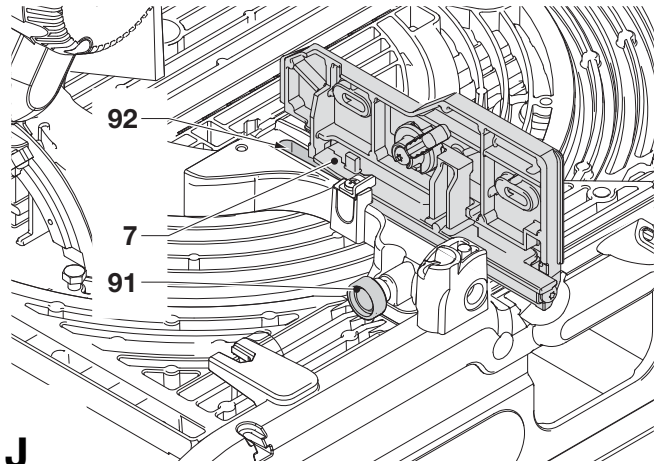

J

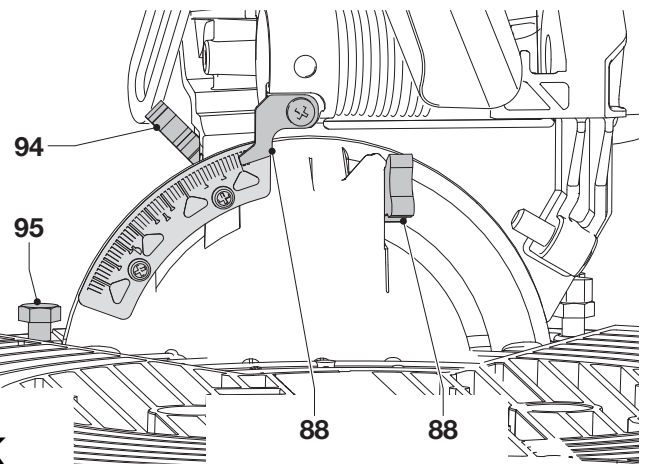

K

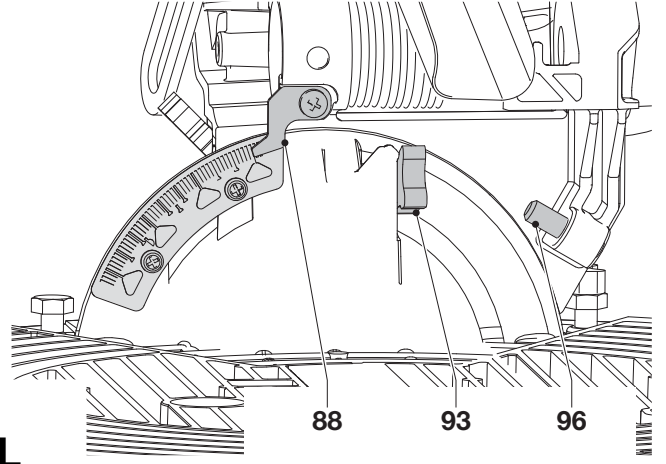

L

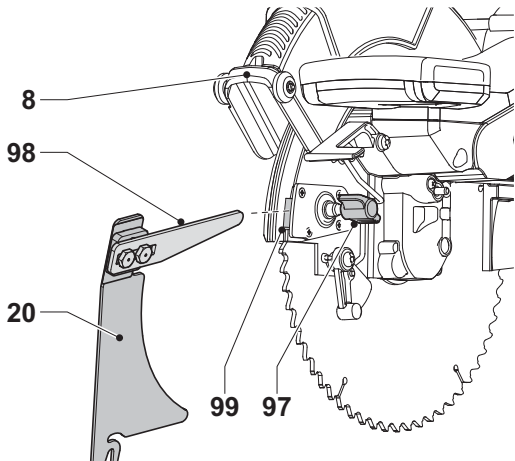

M1

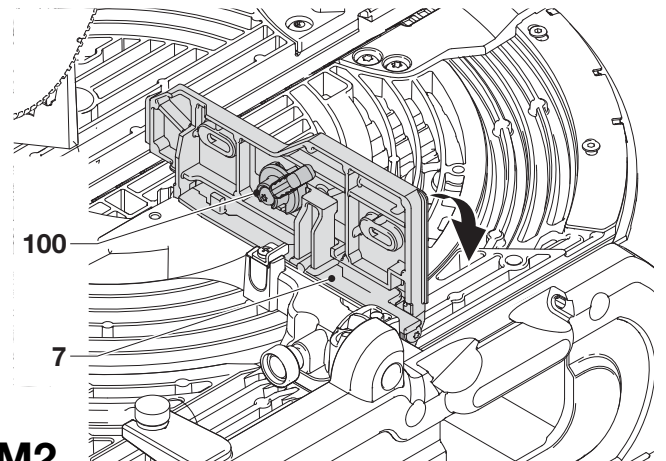

M2

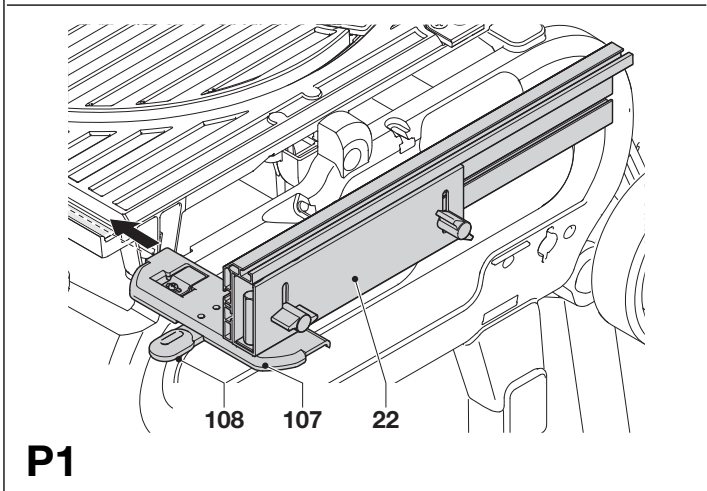
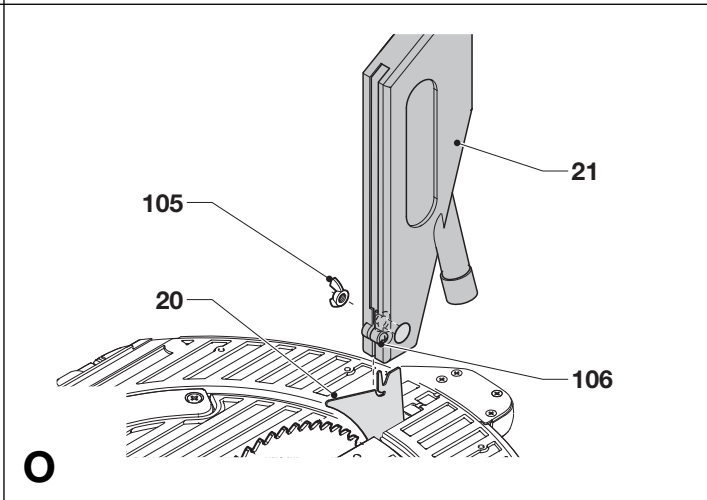
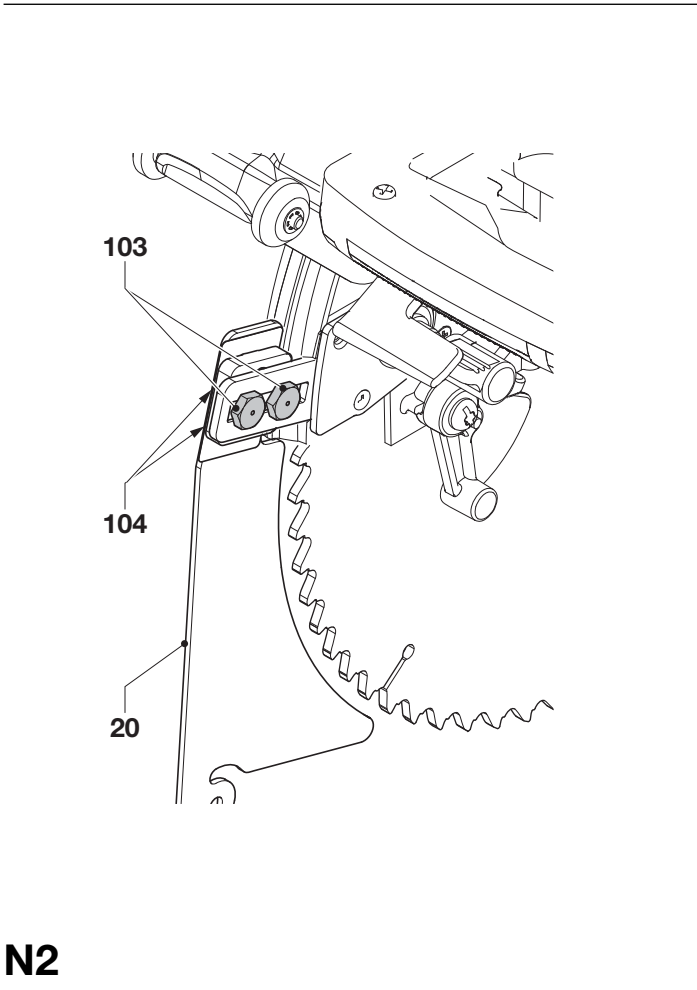
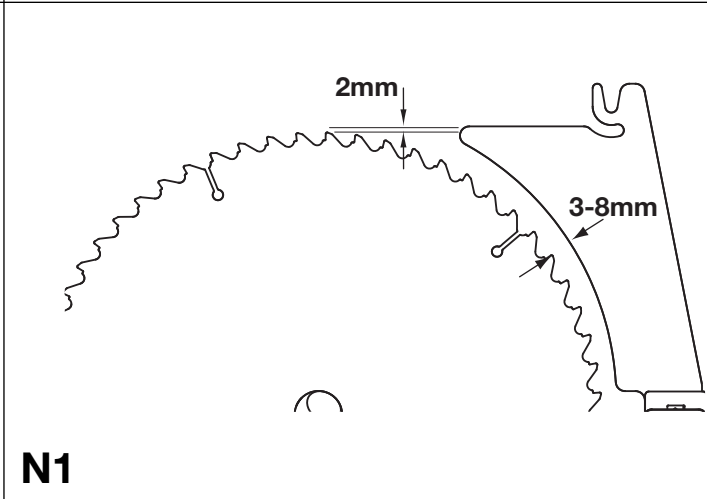
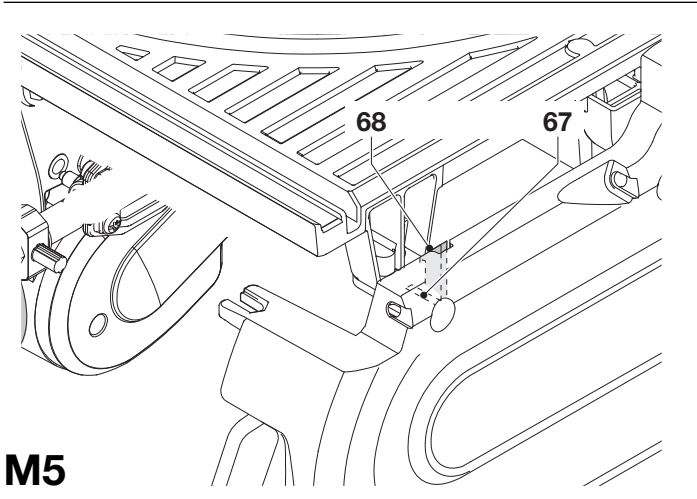
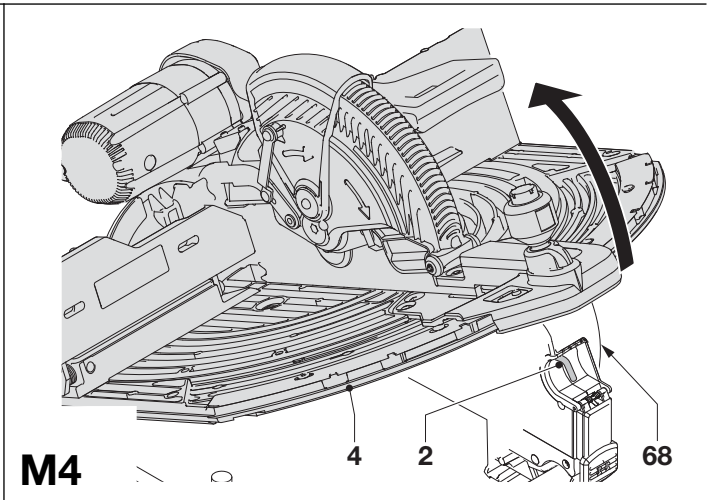
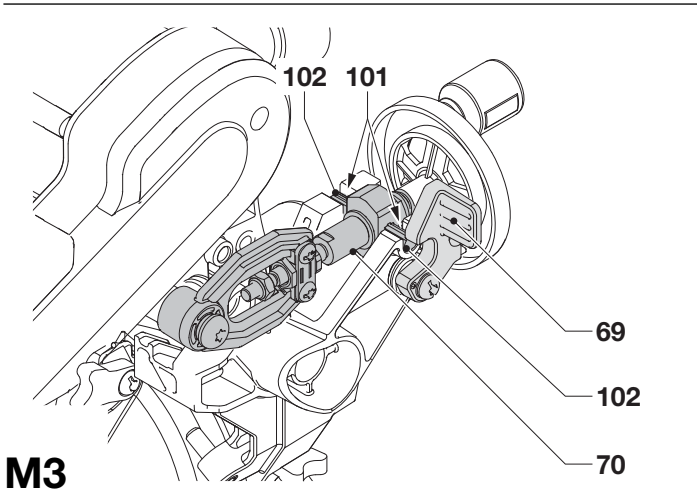

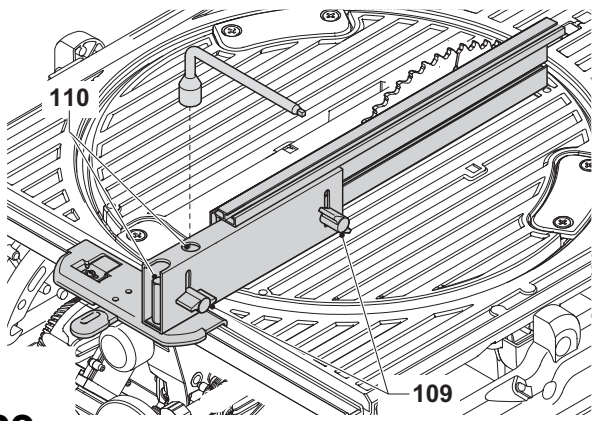

**P2**

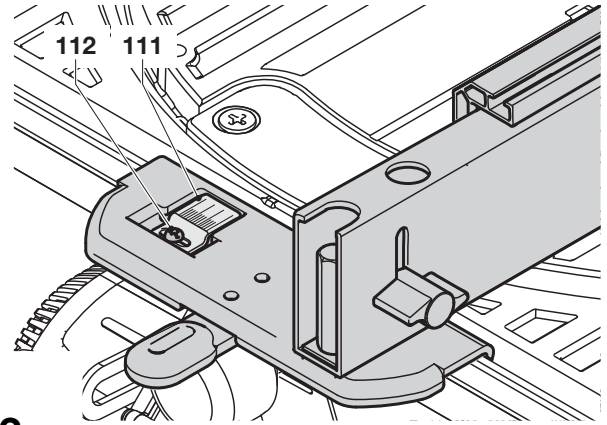

**P3**

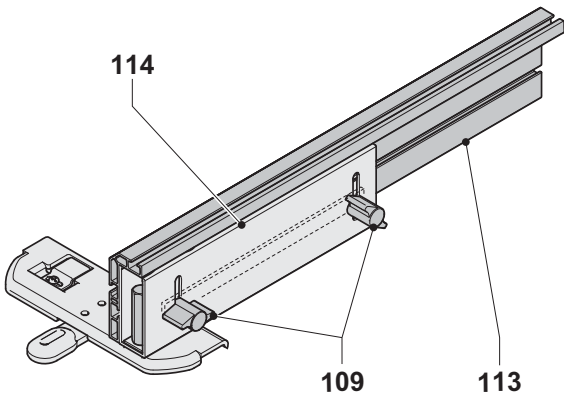

**P4**

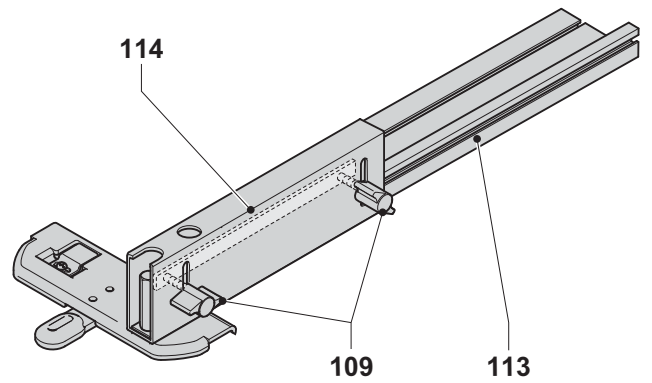

**P5**

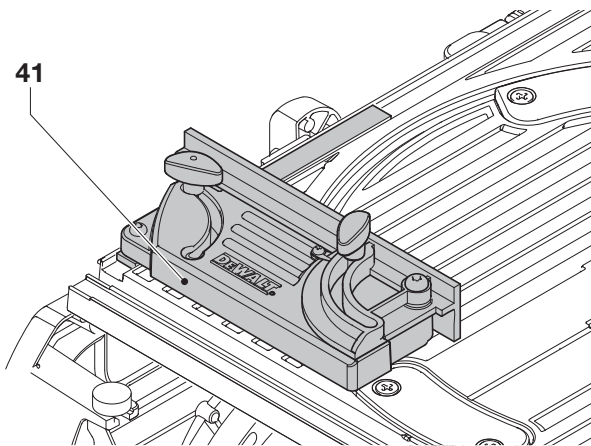

**Q1**

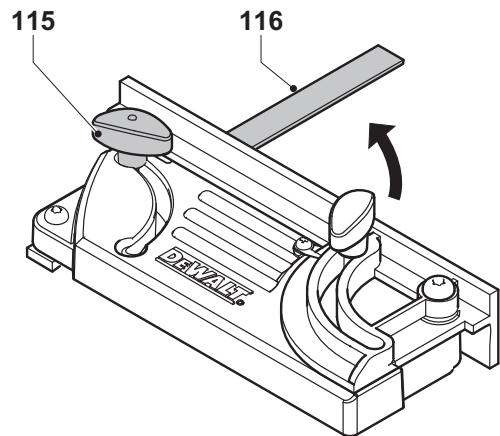

**Q2**

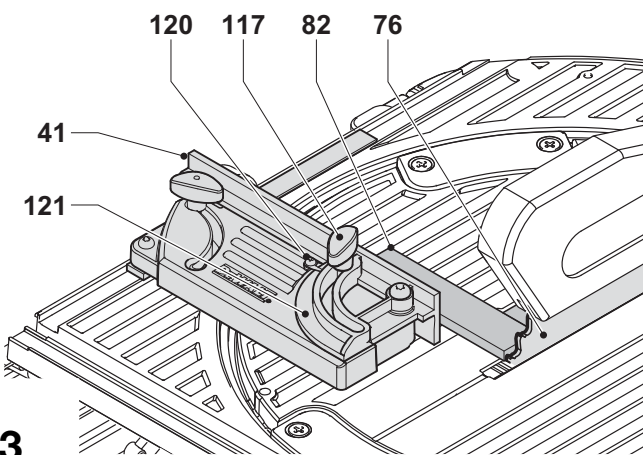

**Q3**

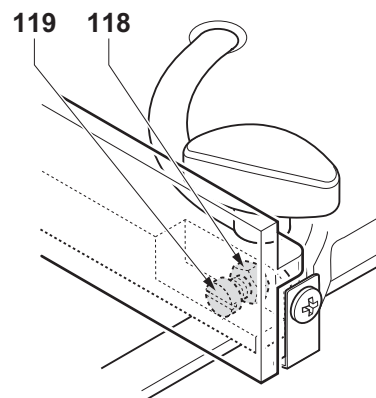

**Q4**

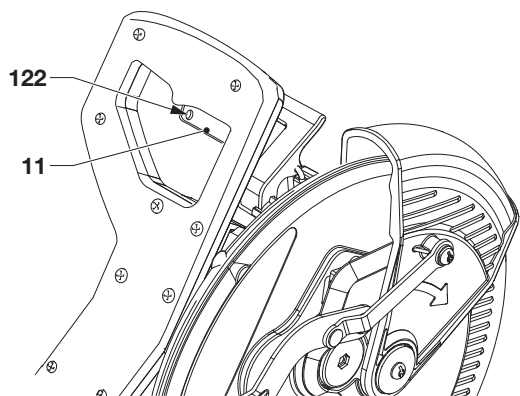

**R1**

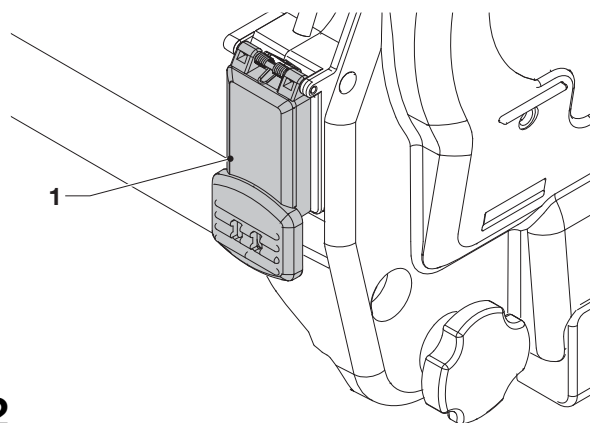

**R2**

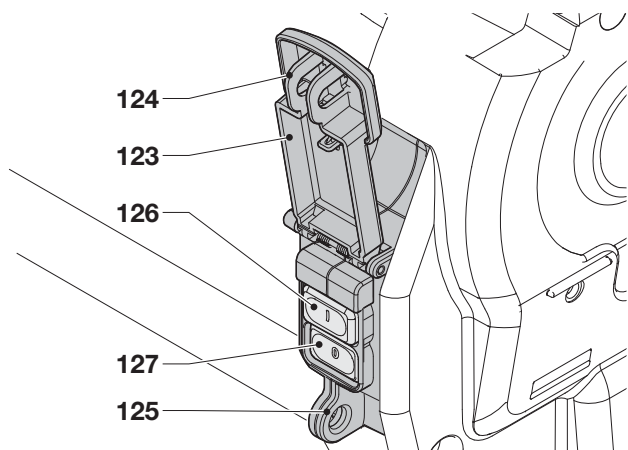

**R3**

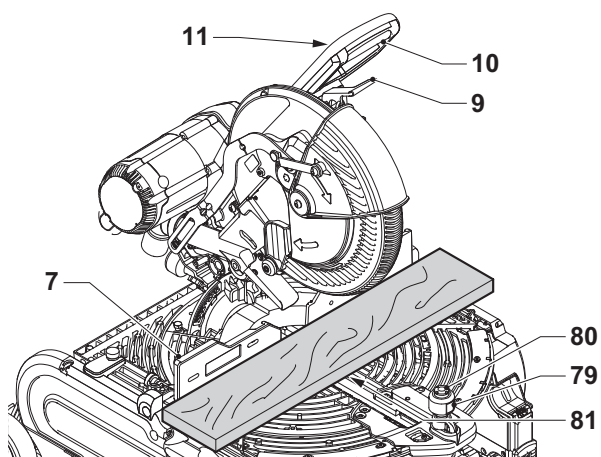

**S1**

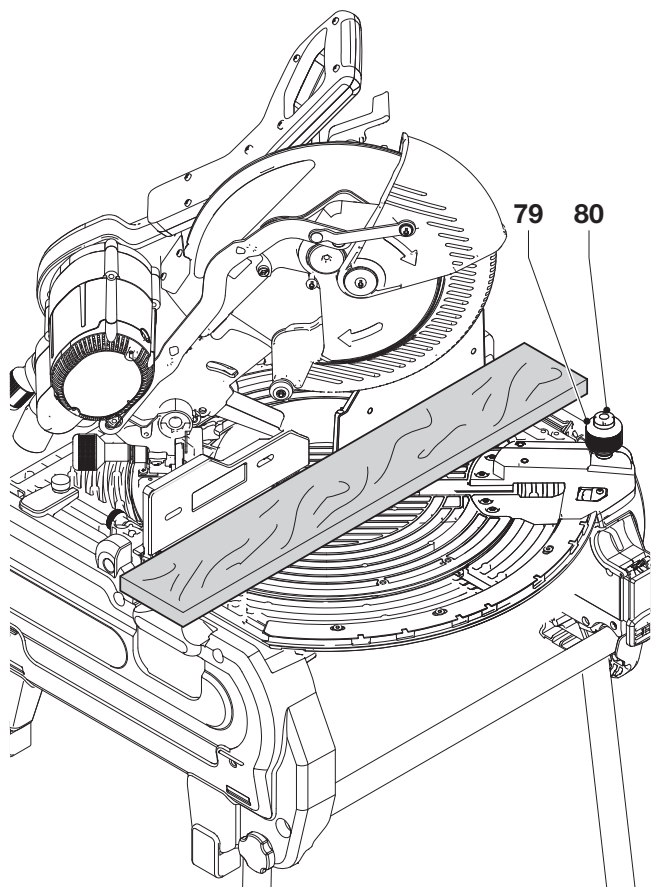

**S2**

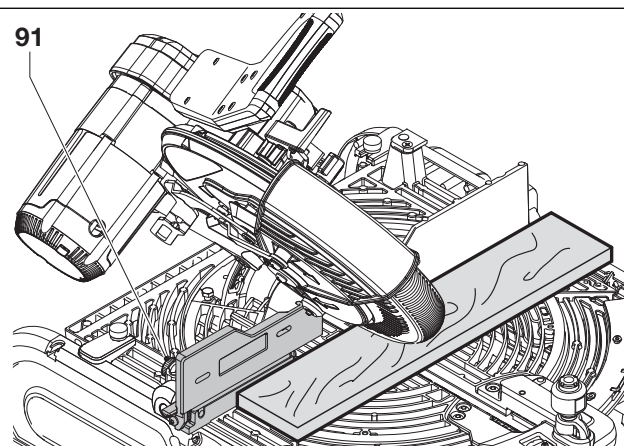

**S3**

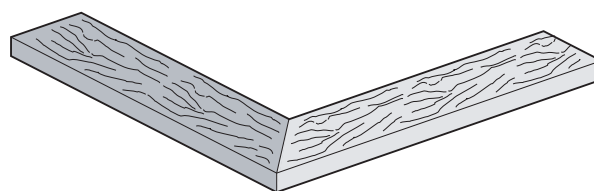

**T1**

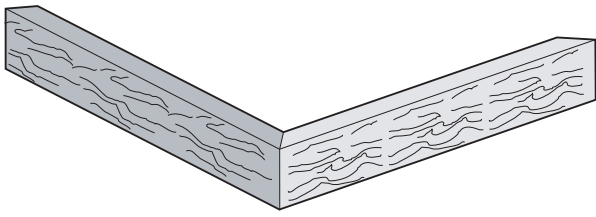

**T2**

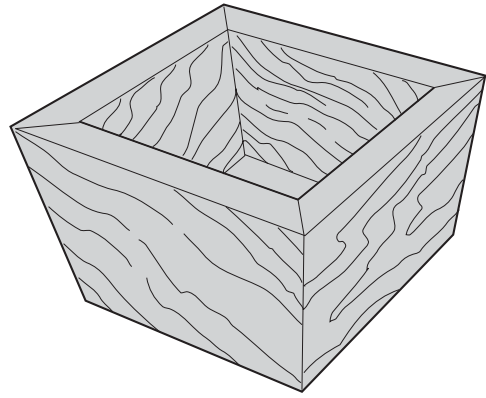

**T3**

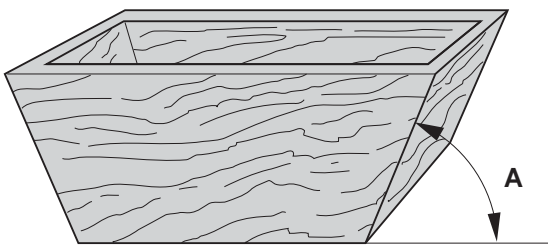

**T4**

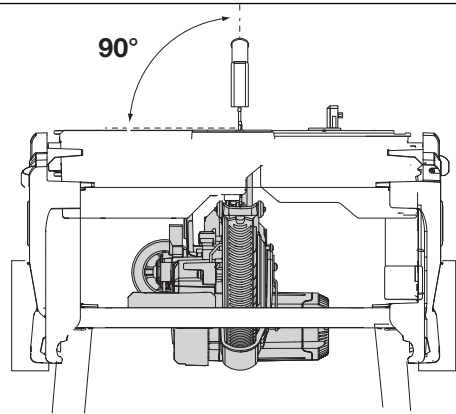

**U1**

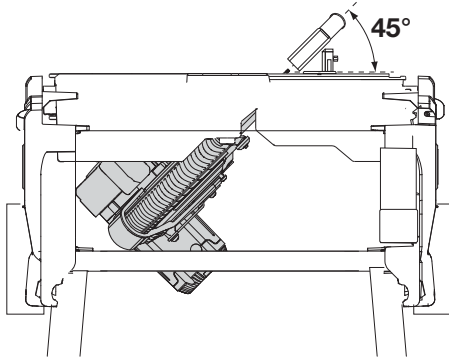

**U2**

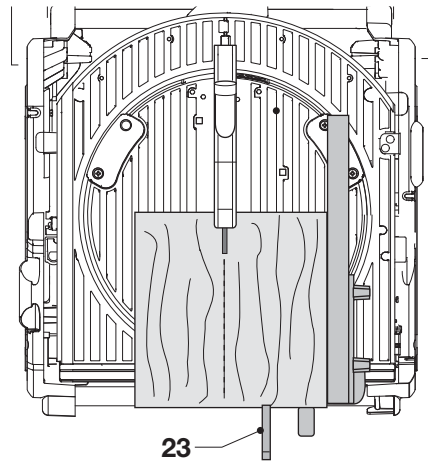

**U3**

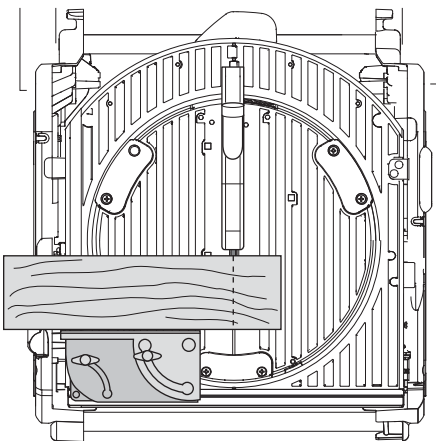

**V1**

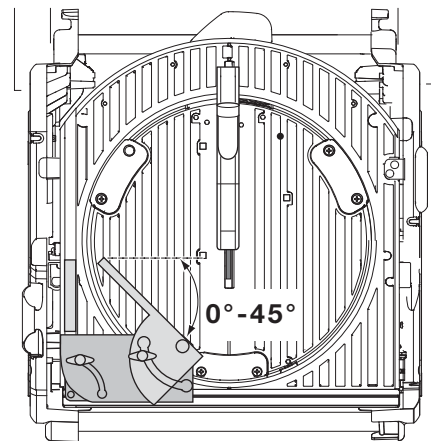

**V2**

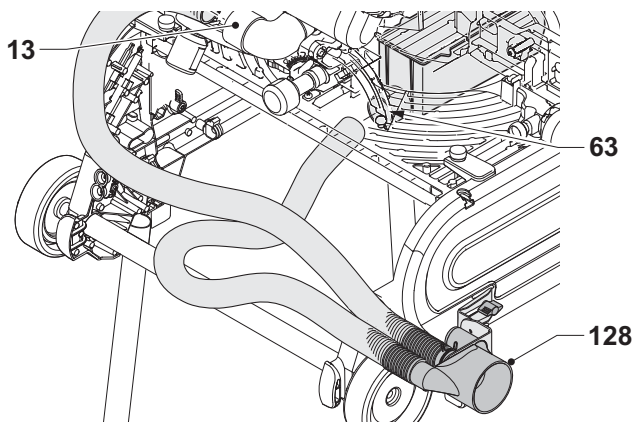

**W1**

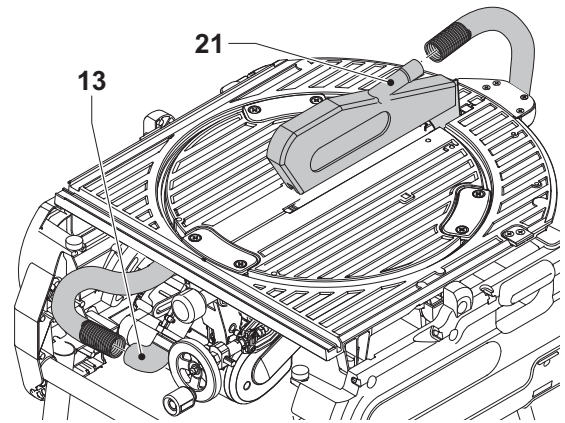

**W2**

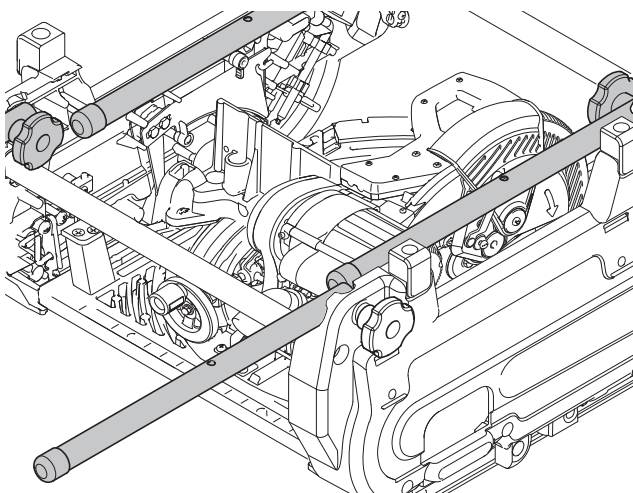

**X**

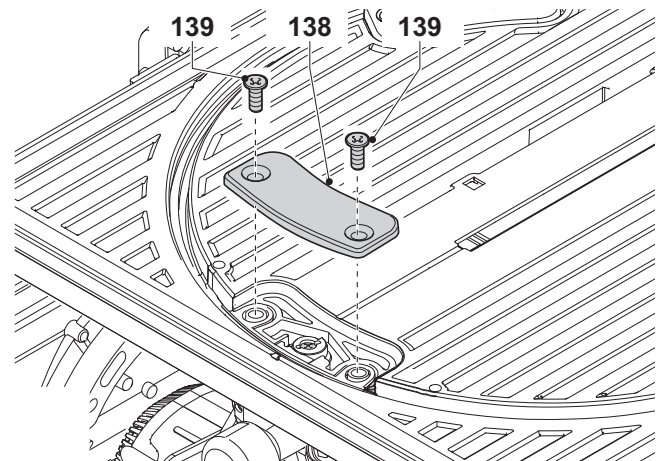

**Y1**

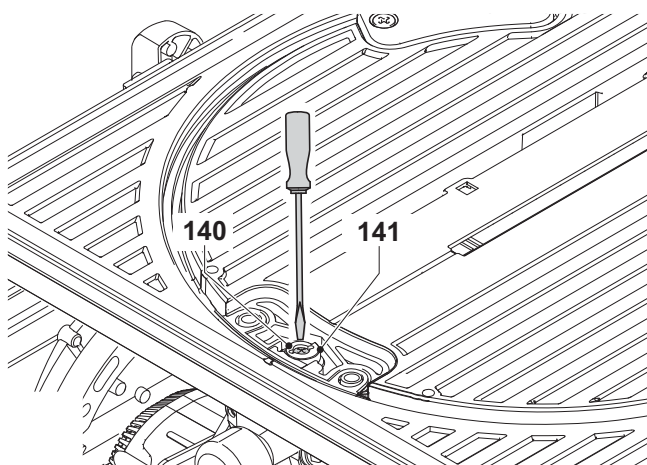

**Y2**

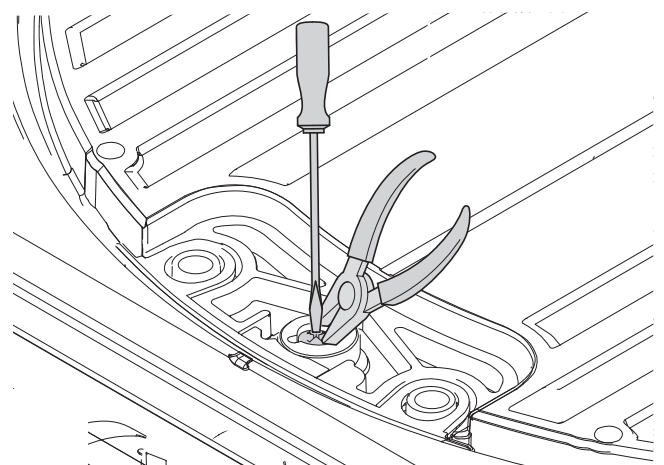

**Y3**

# FLIP-OVER SAW D27105, D27105V

## Congratulations!

You have chosen a DEWALT tool. Years of experience, thorough product development and innovation make DEWALT one of the most reliable partners for professional power tool users.

## Technical data

	D27105/D27105V	
Type		3
Voltage	V	115
Power input	W	1730
Power output	W	860
Max. blade speed	min <sup>-1</sup>	3500
Blade diameter	mm	305
Blade bore	mm	30
Blade body thickness	mm	3.2
Riving knife thickness	mm	2.5
Automatic blade brake time	s	< 10
Weight	kg	42

## Cutting capacities

### Mitre saw mode

Mitre (max. positions)	left	48°
	right	48°
Bevel (max. positions)	left	48°
	right	2°
Max. crosscut capacity at 90°	mm	205
Max. mitre cut capacity at 45°	mm	160
Max. depth of cut 90°	mm	90
Max. depth of bevel cut 45°	mm	60
Max. depth of cut at 45° bevel, 45° mitre	mm	60

### Saw bench mode

Max. ripping capacity left/right	mm	120/320
Depth of cut at 90°	mm	80
Depth of cut at 45°	mm	56

L <sub>pa</sub> (sound pressure)	dB(A)	95.0
K <sub>pa</sub> (sound pressure uncertainty)	dB(A)	3.0
L <sub>wa</sub> (sound power)	dB(A)	106.0
K <sub>wa</sub> (sound power uncertainty)	dB(A)	3.0

Vibration total values (triax vector sum) determined according to EN 61029:

Vibration emission value a <sub>h</sub>		
a <sub>h</sub> =	m/s <sup>2</sup>	2.1
Uncertainty K =	m/s <sup>2</sup>	1.5

The vibration emission level given in this information sheet has been measured in accordance with a standardised test given in EN 61029 and may be used to compare one tool with another. It may be used for a preliminary assessment of exposure.



**WARNING:** The declared vibration emission level represents the main applications of the tool. However if the tool is used for different applications, with different accessories or poorly maintained, the vibration emission may differ. This may significantly increase the exposure level over the total working period.

An estimation of the level of exposure to vibration should also take into account the times when the tool is switched off or when it is running but not actually doing the job. This may significantly reduce the exposure level over the total working period.

Identify additional safety measures to protect the operator from the effects of vibration such as: maintain the tool and the accessories, keep the hands warm, organisation of work patterns.

## Fuses:

U.K. & Ireland 115 V tools 16 Amperes

**NOTE:** This device is intended for the connection to a power supply system with maximum permissible system impedance Z<sub>max</sub> of 0.25 Ω at the interface point (power service box) of user's supply.

The user has to ensure that this device is connected only to a power system which fulfils the requirement above. If necessary, the user can ask the public power supply company for the system impedance at the interface point.

## Definitions: Safety Guidelines

The definitions below describe the level of severity for each signal word. Please read the manual and pay attention to these symbols.



**DANGER:** Indicates an imminently hazardous situation which, if not avoided, **will** result in **death or serious injury**.



**WARNING:** Indicates a potentially hazardous situation which, if not avoided, **could** result in **death or serious injury**.



**CAUTION:** Indicates a potentially hazardous situation which, if not avoided, **may** result in **minor or moderate injury**.

**NOTICE:** Indicates a practice **not related to personal injury** which, if not avoided, **may** result in **property damage**.



Denotes risk of electric shock.



Denotes risk of fire.

## EC-Declaration of Conformity



### D27105/ D27105V

DEWALT declares that these products described under "technical data" are in compliance with:  
2006/42/EC, EN 61029-1, EN 61029-2-11.

These products also comply with Directive 2004/108/EC. For more information, please contact DEWALT at the following address or refer to the back of the manual.

The undersigned is responsible for compilation of the technical file and makes this declaration on behalf of DEWALT.

*H. Grossmann*

Horst Grossmann  
Vice President Engineering and Product Development  
DEWALT, Richard-Klinger-Straße 11,  
D-65510, Idstein, Germany  
29.12.2009

## Safety Instructions



**WARNING!** When using electric tools basic safety precautions should always be followed to reduce the risk of fire, electric shock and personal injury including the following.

Read all these instructions before attempting to operate this product and save these instructions.

### SAVE THIS MANUAL FOR FUTURE REFERENCE

## General Safety Rules

### 1. Keep work area clear.

Cluttered areas and benches invite injuries.

### 2. Consider work area environment.

Do not expose the tool to rain. Do not use the tool in damp or wet conditions. Keep the work area well lit (250 - 300 Lux). Do not use the tool where there is a risk of causing fire or explosion, e.g., in the presence of flammable liquids and gases.

### 3. Guard against electric shock.

Avoid body contact with earthed surfaces (e.g., pipes, radiators, cookers and refrigerators). When using the tool under extreme conditions (e.g., high humidity, when metal swarf is being produced, etc.), electric safety can be improved by inserting an isolating transformer or a (FI) earth-leakage circuit-breaker.

### 4. Keep other persons away.

Do not let persons, especially children, not involved in the work, touch the tool or the extension cord and keep them away from the work area.

### 5. Store idle tools.

When not in use, tools must be stored in a dry place and locked up securely, out of reach of children.

### 6. Do not force the tool.

It will do the job better and safer at the rate to which it was intended.

### 7. Use the right tool.

Do not force small tools to do the job of a heavy duty tool. Do not use tools for purposes not intended; for example do not use circular saws to cut tree limbs or logs.

### 8. Dress properly.

Do not wear loose clothing or jewellery, as these can be caught in moving parts. Non-skid footwear is recommended when working outdoors. Wear protective hair covering to contain long hair.

### 9. Use protective equipment.

Always use safety glasses. Use a face or dust mask if working operations create dust or flying particles. If these particles might be considerably hot, also wear a heat-resistant apron. Wear ear protection at all times. Wear a safety helmet at all times.

### 10. Connect dust extraction equipment.

If devices are provided for the connection of dust extraction and collecting equipment, ensure these are connected and properly used.

### 11. Do not abuse the cord.

**Never yank the cord to disconnect it from the socket.** Keep the cord away from heat, oil and sharp edges. Never carry the tool by its cord.

### 12. Secure work.

Where possible use clamps or a vice to hold the work. It is safer than using your hand and it frees both hands to operate the tool.

### 13. Do not overreach.

Keep proper footing and balance at all times.

### 14. Maintain tools with care.

Keep cutting tools sharp and clean for better and safer performance. Follow instructions for lubricating and changing accessories. Inspect tools periodically and if damaged have them repaired by an authorized service facility. Keep handles and switches dry, clean and free from oil and grease.

### 15. Disconnect tools.

When not in use, before servicing and when changing accessories such as blades, bits and cutters, disconnect tools from the power supply.

### 16. Remove adjusting keys and wrenches.

Form the habit of checking to see that adjusting keys and wrenches are removed from the tool before operating the tool.

### 17. Avoid unintentional starting.

Do not carry the tool with a finger on the switch. Be sure that the tool is in the "off" position before plugging in.

### 18. Use outdoor extension leads.

Before use, inspect the extension cable and replace if damaged. When the tool is used outdoors, use only extension cords intended for outdoor use and marked accordingly.

### 19. Stay alert.

Watch what you are doing. Use common sense. Do not operate the tool when you are tired or under the influence of drugs or alcohol.

### 20. Check for damaged parts.

Before use, carefully check the tool and mains cable to determine that it will operate properly and perform its intended function. Check for alignment of moving parts, binding of moving parts, breakage of parts, mounting and any other conditions that may affect its operation. A guard or other part that is damaged should be properly repaired or replaced by an authorized service centre unless otherwise indicated in this instruction manual. Have defective switches replaced by an authorized service centre. Do not use the tool if the switch does not turn it on and off. Never attempt any repairs yourself.



**WARNING!** The use of any accessory or attachment or performance of any operation with this tool other than those recommended in this instruction manual may present a risk of personal injury.

### 21. Have your tool repaired by a qualified person.

This electric tool complies relevant safety rules. Repairs should only be carried out by qualified persons using original spare parts; otherwise this may result in considerable danger to the user.

## Additional safety rules for mitre saws

- Make sure all locking knobs and clamp handles are tight before starting any operation.
- Do not operate the machine without the guard in position, or if the guard does not function or is not maintained properly.
- Never place either hand in the blade area when the saw is connected to the electrical power source.
- Never attempt to stop a machine in motion rapidly by jamming a tool or other means against the blade; serious accidents can occur.
- Select the correct blade for the material to be cut.
- Never perform any cleaning or maintenance work when the machine is still running and the head is not in the rest position.
- The front section of the guard is louvred for visibility while cutting. Although the louvres dramatically reduce flying debris, there are openings in the guard and safety glasses should be worn at all times when viewing through the louvres.
- Never cut workpiece shorter than 20 mm.
- Without additional support the machine is designed to accept the maximum workpiece size of:
  - Height 63 mm by width 205 mm by length 500 mm
  - Longer workpieces need to be supported by suitable additional table, e.g. DE3474. Always clamp the workpiece safely.

## Additional safety rules for saw benches

- Make sure that the blade rotates in the correct direction and the teeth are pointing to the front of the saw bench.
- Make sure all locking knobs and clamp handles are tight before starting any operation.
- Be sure all blade and flanges are clean and the recessed sides of the collar are against the blade. Tighten the arbor nut securely.
- Use correctly sharpened saw blades. Observe the maximum speed mark on the saw blade



- Never operate the saw without the upper and lower guards in place.
- Never place either hand in the blade area when the saw is connected to the electrical power source.
- Disconnect the saw from the mains before changing blades or carrying out maintenance.
- Use a push stick at all times, and ensure that you do not place hands closer than 150 mm from the saw blade while cutting.
- Do not attempt to operate on anything but the designated voltage.
- Do not apply lubricants to the blade when it is running.
- Do not reach around behind the saw blade.
- Always keep the push stick in its place when not in use.
- Do not stand on top of the unit.
- During transportation make sure that the upper part of the saw blade is covered, e.g. by the guard.
- Do not use the guard for handling or transportation.
- Rebating, slotting or grooving is not allowed.
- Ensure riving knife is adjusted correctly. Never cut without riving knife assembled.  
Never cut work-piece smaller than 30 mm.
- Without additional support the machine is designed to accept the maximum workpiece size of:
  - Height 81 mm by width 400 mm by length 600 mm
  - Longer workpieces need to be supported by suitable additional table, e.g. D271055 or D271058.

#### Additional safety rules for flip-over saws

- Ensure that the arm is securely fixed in the working position in the bench sawing mode.
- Ensure that the arm is securely fixed when bevelling in the bench saw mode.
- Ensure the table is correctly locked when changing the saw mode.
- Never saw ferrous or non-ferrous materials when ripping in the bench saw mode.
- Before using any accessory consult the instruction manual. The improper use of an accessory can cause damage.
- Observe the maximum speed marked on the saw blade.
- Use a holder or wear gloves when handling a saw blade.
- Ensure that the blade rotates in the correct direction. Keep the blade sharp.
- The max. allowable speed of the saw blade must always be equal to or greater than the no-load speed of the tool specified on the nameplate.
- Do not use saw blades that do not conform to the dimensions stated in the technical data. Do not use any spacers to make a blade fit onto the spindle. Use only the blades specified in this manual, complying with EN 847-1.
- Consider applying specially designed noise-reduction blades.
- Do not use HSS blades.
- Do not use cracked or damaged saw blades.
- After completing the cut, release the switch and wait for the saw blade to come to a complete stillstand before returning the head to its upper rest position.
- Ensure that the arm is securely fixed when performing bevel cuts.
- Do not wedge anything against the fan to hold the motor shaft.
- The blade guard on your saw will automatically raise when the arm is brought down; it will lower over the blade when the arm is raised. The guard can be raised by hand when installing or removing saw blades or for inspection of the saw. Never raise the blade guard manually unless the saw is switched off.
- Keep the surrounding area of the machine well maintained and free of loose materials, e.g. chips and cut-offs.
- Check periodically that the motor air slots are clean and free of chips.
- Disconnect the machine from the mains before carrying out any maintenance work or when changing the blade.
- Do not use saw blades with a body thickness greater or a width of tooth smaller than the thickness of the riving knife.
- Make sure the machine is placed on an even surface with sufficient stability.
- Do not use abrasive or diamond disc.
- In case of an accident or machine failure immediately switch the machine off and disconnect from power source.  
Report the failure and mark the machine in suitable form to prevent other persons from using the defective machine.
- When the saw blade is blocked due to abnormal feed force during cutting, turn the machine off and disconnect it from power supply. Remove the workpiece and ensure that the saw blade runs free. Turn the machine on and start new cutting operation with reduced feed force.
- Refrain from removing any cut-offs or other parts of the workpiece from the cutting area while the machine is running and the saw head is not in the rest position
- Do not use the machine without the legs mounted.
- Make sure your position is always left or right of the cutting line.
- Provide adequate general or localized lighting.
- Ensure the operator is adequately trained in the use, adjustment and operation of the machine.
- Switch the machine off when unattended.
- A laser to indicate the cutting line is supplied with the D27107V, the laser is of class 2 according to EN 60825-1. Do not replace a laser diode with a different type. If damaged, have the laser repaired by an authorised repair agent.
- Connect the saw to a dust collection device when sawing wood. Always consider factors which influence exposure of dust such as:
  - type of material to be machined (chip board produces more dust than wood);
  - sharpness of the saw blade;
  - correct adjustment of the saw blade,
  - dust extractor with air velocity not less than 20 m/s.
 Ensure that the local extraction as well as hoods, baffles and chutes are properly adjusted.
- Never cut light alloy, especially magnesium.

#### Residual risks

The following risks are inherent to the use of saws:

- injuries caused by touching the rotating parts

In spite of the application of the relevant safety regulations and the implementation of safety devices, certain residual risks cannot be avoided.

These are:

- Impairment of hearing.
- Risk of accidents caused by the uncovered parts of the rotating saw blade.
- Risk of injury when changing the blade.
- Risk of squeezing fingers when opening the guards.
- Health hazards caused by breathing dust developed when sawing wood, especially oak, beech and MDF.

The following factors are of influence to noise production:

- The material to be cut
- The type of saw blade
- The feed force

The following factors increase the risk of breathing problems:

- No dust extractor connected when sawing wood
- Insufficient dust extraction caused by uncleaned exhaust filters
- Worn saw blade
- Workpiece not exactly guided

## Markings on Tool

The following pictograms are shown on the tool:



Read instruction manual before use.



Wear ear protection.



Wear eye protection.



Carrying Point



Hands Away

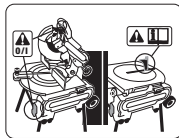

When using the machine in the mitre saw mode, make sure to operate the trigger switch in the handle when switching ON and OFF. Do not operate the switchbox in this mode. The ON/OFF switch located to machine frame is foreseen for table saw mode only.



When using the machine in the mitre saw mode, make sure the riving knife is secured in its rest position.



Never use as mitre saw when the guard is not in place.

### DATE CODE POSITION (FIG. A1)

The Date Code (143), which also includes the year of manufacture, is printed into the housing.

Example:

2010 XX XX  
Year of Manufacture

### Package contents

The package contains:

- 1 Partly assembled machine
- 1 Box containing:
  - 1 Top guard for bench saw position
  - 1 Under-table guard for mitre saw position
  - 4 Legs
  - 2 Wheels
  - 4 Feet
  - 1 Parallel fence
- 1 Instruction manual
- 1 Exploded drawing

- Check for damage to the tool, parts or accessories which may have occurred during transport.
- Take the time to thoroughly read and understand this manual prior to operation.

## Description (fig. A1 - A11)

### A1

- 1 On/off switch (saw bench mode)
- 2 Table release lever
- 3 Rotating table clamp
- 4 Mitre saw table
- 5 Rotating table
- 6 Fence right-hand side
- 7 Fence left-hand side
- 8 Moveable lower blade guard
- 9 Guard release lever
- 10 Operating handle
- 142 Circuit breaker reset button
- 143 Date code

### A2

- 10 Operating handle
- 11 Trigger switch (mitre saw mode)
- 12 Fixed upper blade guard
- 13 Dust extraction adapter
- 14 Wheel
- 15 Leg
- 16 Foot
- 17 Bevel clamp handle

### A3

- 17 Bevel clamp handle
- 18 Height adjuster
- 19 Saw bench table
- 20 Riving knife
- 21 Upper blade guard
- 22 Parallel fence
- 23 Push stick

### Optional accessories

#### A4

For use in mitre saw mode:

- 30 Fence insert (DE7120)

#### A5

- 31 Adjustable stand 760 mm (max. height) (DE3474)
- 32 Support guide rails 1,000 mm (DE3494)
- 33 Support guide rails 500 mm (DE3491)
- 34 Inclinable support (DE3495)
- 35 Swivelling stop (DE3462)
- 36 Length stop for short workpieces (to be used with guide rails [33]) (DE3460)
- 37 Support with removable stop (DE3495)
- 38 Support with stop removed (DE3495)
- 39 Material clamp (D271051)

#### A6

- 40 Roller support table (DE3497)

For use in saw bench mode:

#### A7

- 41 Mitre fence (D271052)

#### A8

- 42 Extension table (D271058)

#### A9

- 43 Sliding table (D271055)  
Push sticks (DE3454) (not shown)

For use in all modes:

#### A10

44 Three way dust extraction kit (D271054)

#### A11

144 Laser

### INTENDED USE

Your DeWALT D27105 flip-over saw has been designed to operate as a mitre saw or a saw bench to perform the four main sawing operations of ripping, cross-cutting, bevelling and mitring easily, accurately and safely.

This unit is designed for use with a nominal blade diameter 305 mm carbide tip blade for professional cutting wood, wood products and plastics.

**DO NOT** use under wet conditions or in presence of flammable liquids or gases.

These flip over saws are professional power tools.

**DO NOT** let children come into contact with the tool. Supervision is required when inexperienced operators use this tool.



**WARNING!** Do not use the machine for purposes other than intended.

#### Mitre saw mode

In mitre saw mode, the sawing machine is used in vertical, mitre or bevel position.

#### Saw bench mode

Turned over on its central axis, the sawing machine is used to perform the standard ripping operation and for sawing wide pieces by manually feeding the workpiece into the blade.

### Electrical Safety

The electric motor has been designed for one voltage only. Always check that the power supply corresponds to the voltage on the rating plate.



Your tool is double insulated in accordance with EN 61029; therefore no earth wire is required.



**WARNING:** 115 V units have to be operated via a fail-safe isolating transformer with an earth screen between the primary and secondary winding.

In case of cord replacement the tool must only be repaired by an authorized service agent or by qualified electrician.

### Fitting a Mains Plug to 115 V Units (U.K. and Ireland Only)

- The plug fitted should comply with BS EN 60309 (BS4343), 16 Amps, earthing contact position 4h.



**WARNING:** Always ensure that the cable clamp is correctly and securely fitted to the sheath of the cable.

### Using an Extension Cable

If an extension cable is required, use an approved 3-core extension cable suitable for the power input of this tool (see technical data).

The minimum conductor size is 1.5 mm<sup>2</sup>. When using a cable reel, always unwind the cable completely.

### ASSEMBLY



**WARNING:** To reduce the risk of injury, turn unit off and disconnect machine from power source before installing and removing accessories, before adjusting or changing set-ups or when making repairs. Be sure the trigger switch is in the OFF position. An accidental start-up can cause injury.

#### Unpacking the machine and its parts.



**WARNING:** To reduce the risk of injury, always seek assistance when moving the machine.

- Remove the loose packaging material from the box.

- Lift the machine out of the box.
- Remove the parts box from the interior of the machine.
- Remove any remaining packing material from the machine.

#### Mounting the feet (fig. B, B1)

With the feet and legs mounted, alternatively the machine is suitable for placement on a workbench. To ensure a safe operation, the machine must be fastened to the workbench.



**WARNING!** Do never operate this machine when it is not fastened to the workbench. The feed force will make the saw unstable if not fastened to the workbench.

- Turn the machine upside down
- Place a foot (16) on each of the mounting locations (51) on the base
- Slide a nut (52) into the slots (53) located above the mounting locations
- Insert a bolt (54) fitted with a washer (55) into the feet
- Tighten the bolts
- Mount the legs as described below.
- Fold the legs as described below
- Turn the machine straight up
- Insert a bolt of 8 mm and 120 mm minimum length (49) into the feet on each mounting location (fig. B1).
- Tighten the bolts

#### Mounting the legs (fig. C1 & C2)

With the legs mounted, the machine is suitable for stand-alone placement.

- Turn the machine upside down.
- Mount the legs as described below. Beware that the front legs and the rear legs have different lengths. The rear legs are slightly longer than the front legs. Make sure to mount the legs in the correct place.
- Turn the machine straight up. Make sure it is level; adjust the leg clamping height if required.

#### Rear legs

- Present a leg (15) to each of the mounting points (56) located at the lower edges on the inside of the base (fig. C1).
- Pass a coach bolt (57) from the outside through the holes into the frame and the legs.
- Place a bracket (58) and a lock knob (59) onto the bolts.
- Tighten the lock knobs.

#### Front legs

- Present a leg (15) to each of the mounting points (56) located at the upper edges on the inside of the base (fig. C2).
- Place a bracket (58) over the legs.
- Pass a coach bolt (57) from the inside through the holes into the brackets, the legs and frame.
- Place a lock knob (59) onto the bolts.
- Tighten the lock knobs.

#### Folding the legs (fig. C3)

The legs can be folded into the base to make the machine suitable for use on a workbench.

- Turn the machine upside down.
- Loosen the lock knob (59) of the first leg (15).
- Fold the leg inwards.
- Tighten the lock knob.
- Repeat as for the other legs.
- Turn the machine straight up.

#### Mounting the wheels (fig. D)

- Place a wheel (14) onto the axles (60) on each side of the machine.
- Place a flat washer (61) and a nut (62) onto the threaded end of the axles.
- Tighten the nuts using the spanner supplied.

## Assembly for mitre saw mode

### Mounting the under-table guard (fig. E)

The under-table guard (63) is fitted to the top of the saw bench table.

- Place the two fasteners on the left of the guard into the slots (64) on the left of the blade slot (65). Turn the plastic screws counterclockwise.
- Place the guard flat on the table and press the fastener in the slot (66) on the right of the blade slot. Turn the plastic screw counterclockwise.
- To remove, turn the screws clockwise and remove the guard.

### Turning the sawhead and table over (fig. F1 - F4)

- Withhold the saw table (19) with one hand and push the table release lever (2) to the right (fig. F1).
- Push the table downwards at the front (fig. F2) and swing it over completely until the motor assembly is uppermost and the plate (67) engages in the table locking device (68) (fig. F3).
- Push the release lever (69) to the rear whilst holding down the head until the spring-loaded bearing unit (70) can be lifted out of its seating (fig. F4).
- Flip the bearing unit up.
- Holding the head firmly, allow the spring pressure to take the head upwards into its rest position.

### Mounting the saw blade (fig. G1 - G4)



**WARNING: To reduce the risk of injury, turn unit off and disconnect machine from power source before installing and removing accessories, before adjusting or changing set-ups or when making repairs. Be sure the trigger switch is in the OFF position. An accidental start-up can cause injury.**

- Always change blades with the machine in mitre saw mode.
- Never depress the spindle lock button while the blade is under power or coasting.
- Do not cut ferrous metal (containing iron or steel) or masonry or fibre cement product with this mitre saw.
- The teeth of a new blade are very sharp and can be dangerous.
- Always change blades with the machine in mitre mode.
- Depress the head lock up release lever (9) to release the lower guard (8), then raise the lower guard as far as possible (Fig. G1).
- With the lower guard held in the raised position, depress the spindle lock button (74) with one hand, then use the supplied blade spanner in the other hand to loosen the left-hand threaded blade locking screw (73) by turning clockwise.



**WARNING! To use the spindle lock, press the button as shown and rotate the spindle by hand until you feel the lock engage.**

Continue to hold the lock button in to keep the spindle from turning (74, fig. G1).

- Remove the blade locking screw (73) and the outside arbor collar (75).
- Install the saw blade (76) onto the shoulder (77) provided on the inside arbor collar (78), making sure that the teeth at the bottom edge of the blade are pointing toward the back of the saw (away from the operator).
- Replace the outer arbor collar (75).
- Tighten the blade locking screw (73) carefully by turning counterclockwise while holding the spindle lock engaged with your other hand.
- Raise the lower guard.



**WARNING! Be aware the saw blade shall be replaced in the described way only. Only use saw blades as specified under Technical Data; Cat.no.: DT4260 is suggested.**

### Adjustments for mitre saw mode

Your mitre saw was accurately adjusted at the factory. If readjustment due to shipping and handling or any other reason is required, follow the steps below to adjust your saw. Once made, these adjustments should remain accurate.

### Checking and adjusting the blade to the fence (fig. H1 - H3)

- Loosen the mitre knob (79) and depress the mitre latch (80) to release the rotating table (5) (fig. H1).
- Swing the rotating table until the latch locates it at the 0° mitre position. Do not tighten the knob.
- Pull down the head until the blade just enters the saw kerf (81).
- Place a square (82) against the left side (7) of the fence and blade (76) (fig. H2).



**WARNING: Do not touch the tips of the blade teeth with the square.**

- If adjustment is required, proceed as follows:
- Loosen the screws (83) (fig. H3) and move the scale/rotating table assembly left or right until the blade is at 90° to the fence as measured with the square (fig. H2).
- Retighten the screws (83) (fig. H3). Pay no attention to the reading of the mitre pointer at this point.

### Adjusting the mitre pointer (fig. H1 & H4)

- Loosen the mitre knob (79) and depress the mitre latch (80) to release the rotating table (5) (fig. H1).
- With the mitre knob loose, allow the mitre latch to snap into place as you rotate the mitre arm past zero.
- Observe the pointer (84) and mitre scale (85) (fig. H4). If the pointer does not indicate exactly zero, loosen the screw (86), move the pointer to read 0° and tighten the screw.

### Checking and adjusting the blade to the table (fig. I1 - I3)

- Loosen the bevel clamp knob (17) (fig. I1).
- Press the saw head to the right to ensure it is fully vertical and tighten the bevel clamp handle.
- Pull down the head until the blade just enters the saw kerf (81).
- Place a set square (82) on the table and up against the blade (76) (fig. I2).



**WARNING: Do not touch the tips of the blade teeth with the square.**

- If adjustment is required, proceed as follows:
- Loosen the bevel clamp knob (17) (fig. I1) and turn the vertical position adjustment stop screw (87) (fig. I3) in or out until the blade is at 90° to the table as measured with the square (fig. I2).
- If the bevel pointer (88) does not indicate zero on the bevel scale (89), loosen the screw (90) that secures the pointer and move the pointer as necessary (fig. I3).

### Adjusting the fence (fig. J)

The upper part of the left side of the fence can be adjusted to the left to provide clearance, allowing the saw to bevel to a full 48° left. To adjust the fence (7):

- Loosen the fence clamping knob (91) and slide the upper part of the side fence to the left.
- Make a dry run with the saw switched off and check for clearance. Adjust the fence to be as close to the blade as practical to provide maximum workpiece support, without interfering with the up and down movement of the arm.
- Tighten the knob securely.



**WARNING: The guide groove (92) can become clogged with sawdust. Use a stick or some low pressure air to clear the guide groove.**

### Checking and adjusting the bevel angle (fig. I1, J K & L)

- Loosen the fence clamping knob (91) and slide the upper part of the side fence to the left as far as it will go (fig. J).
- Loosen the bevel clamp knob (17) (fig. I1) and with the intermediate bevel position stop (93) turned aside move the saw arm to the left until the angle position stop (94) rests against the bevel position adjustment stop (95) (fig. K). This is the 45° bevel position.

- If adjustment is required, proceed as follows:
- Turn the bevel position adjustment stop screw (95) in or out as necessary until the pointer (88) indicates 45° with the angle position stop resting against the bevel position adjustment stop.

#### Checking and adjusting the intermediate bevel angle (fig. I1, J & L)

The intermediate bevel angle is preset at 30°, enabling a quick setting for the cutting of crown moulding.

- Loosen the fence clamping knob (91) and slide the upper part of the side fence to the left as far as it will go (fig. J).
- Loosen the bevel clamp knob (17) (fig. I1) and with the intermediate bevel position stop (93) turned into place move the saw arm to the left until the angle position adjustment stop (96) rests on the intermediate bevel position stop (93) (fig. L). This is the 30° bevel position.
- If adjustment is required, proceed as follows:
- Turn the bevel position adjustment stop screw (96) in or out as necessary until the pointer (88) indicates 30° with the bevel position adjustment stop resting on the intermediate bevel position stop.

### Assembly for saw bench mode

#### Changing from mitre saw to saw bench mode (fig. A1, M1 - M5)

- Put the blade into 0° cross-cut position with the rotating table clamp (3) secured (fig. A1).
- Slacken the riving knife clamp knob (97) just enough to allow the riving knife to enter the mounting slot (fig. M1).
- Remove the riving knife (20) from its storage position in the inside of the base.
- Depress the guard release lever (9) to release the blade guard (8), then raise the blade guard as far as possible (fig. A1).
- Slide the riving knife bracket (98) into the mounting slot (99) (fig. M1). Tighten the clamp knob.
- Push the lever (100) to allow the spring loaded upper part of the fence (7) to rest against the rotating table (fig. M2)
- Pull down the sawhead.
- Push the release lever (69) to the rear (fig. M3).
- Push the bearing unit (70) down until notches (101) engage in the locations (102) (fig. M3).



**WARNING:** The blade should not foul the lower blade guard.

- Pull the table release lever (2) to the right, lift the front edge of the table (4) (fig. M4) and flip it back through 180° until the plate of the table-locking device (68) automatically engages the latch of the table locking device to secure it in the saw bench mode (fig. M5).
- Remove the under-table guard.

#### Adjusting the riving knife (fig. N1 & N2)



**WARNING:** When adjustments to the riving knife (20) are to be made, it is best to rotate the unit in mitre saw mode (fig. N2). Proceed as described in the section "Changing from saw bench to mitre saw mode".

The correct position is for the top of the riving knife to be no more than 2 mm below the highest tooth of the blade and the body of the radius to be a maximum of 3 - 8 mm from the tips of the saw blade teeth (fig. N1).

- If adjustment is required, proceed as follows:
- Slacken the bolts (104) to adjust the horizontal position of the riving knife.
- Slacken the bolts (103) to adjust the vertical position of the riving knife.
- Securely tighten the bolts.

#### Fitting the upper blade guard (fig. O)

The upper blade guard (21) is designed to be quickly and easily attached to the riving knife (20) once the machine has been set up for saw bench mode.

- Loosen the wingnut (105).

- Holding the guard vertically, align the slot in the rear of the guard with the riving knife.
- Lower the guard over the riving knife (20), making sure that the shaft of the bolt enters the recess.
- Turn the guard into horizontal position, which will lock the guard to the riving knife by the locating screw (106).
- Tighten the wingnut.



**WARNING:** Never use your saw in saw bench mode without the upper guard correctly fitted.

#### Mounting and adjusting the parallel fence (fig. P1 - P5)

The parallel fence (22) can be mounted on either side of the blade.

- Slide the bracket (107) on from the left or the right (fig. P1). The clamping plate engages behind the front edge of the table.
- Slide the fence up against the blade.
- Push the lever (108) down to secure the fence in place.
- Check that the fence is parallel to the blade.
- If adjustment is required, proceed as follows:
- Loosen the lock knobs (109) and slide the fence backwards in order to obtain access to the adjustment bolts (110) in the top of the fence (fig. P2).
- Using the spanner, loosen the adjustment bolts fastening the fence bracket to the fence support.
- Adjust the fence so that it is parallel to the blade by checking the distance between the blade and the fence at the front and rear of the blade.
- When the adjustment has been carried out, re-tighten the adjustment bolts and check again that the fence is parallel to the blade.
- Check that the pointer (111) indicates zero on the scale (fig. P3). If the pointer does not indicate exactly zero, loosen the screw (112), move the pointer to read 0° and tighten the screw.

The default set-up of the fence is to the right-hand side of the blade.

To prepare the fence for use to the left-hand side of the blade, proceed as follows (fig. P4):

- Remove the lock knobs (109).
- Slide the fence profile (113) out of the clamping support.
- Turn the clamping support (114) round and re-fit the lock knobs.
- Slide the fence onto the clamping support.
- Tighten the knobs.

The fence is reversible: the workpiece can be guided along the 75 mm or along the 11 mm face to allow the use of a push stick when ripping thin workpieces (fig P5).

- To set for 11 mm, loosen the fence clamping knobs (109) and slide the fence (113) out of the clamping support (114).
- Turn the fence and re-engage the clamping support in the slot as shown (fig. P5).
- To use with the full height of 75 mm, slide the fence into the clamping support with the wide face in the vertical position (fig. P4).



**WARNING:** Use the 11 mm profile for ripping low workpieces to allow access between the blade and the fence for the push stick. The rear end of the fence should be level with the front of the riving knife.

#### Mounting and adjusting the mitre fence (fig. Q1 - Q4)

The mitre fence (D271052) is available as an option. The mitre fence (41) can be used for mitre cutting when the machine is in saw bench mode (fig. Q1).

- Loosen the clamp knob (115) and swing the guide bar (116) out (fig. Q2). Tighten the clamp knob.
- Slide the fence on the left side on the table (fig. Q3).
- Loosen the lock knob (117).
- Place a square (82) against the fence (41) and the blade (76).
- If adjustment is required, proceed as follows:
- Loosen the nut (118) a few turns and turn the right angle adjustment stop screw (119) (fig. Q4) in or out until the fence is at 90° to the blade as measured with the square (fig. Q3).

- Tighten the knob (117).
- Check that the pointer (120) indicates zero on the scale (121).  
Adjust if necessary.

**Changing from saw bench to mitre saw mode (fig. A3, E & M1)**

- Remove the parallel fence (22), or the mitre fence, if fitted (fig. A3).
- Remove the upper blade guard (21).
- Replace the under-table guard (63) (fig. E).
- Proceed as described in the section "Turning the sawhead and table over".
- Slacken the riving knife clamp knob (97) and remove the riving knife (20), while holding the blade guard (8) (fig. M1).
- Lower the blade guard.
- Place the riving knife in its storage position in the inside of the base.

**OPERATION**

**Instructions for Use**



**WARNING:** Always observe the safety instructions and applicable regulations.

- Ensure the material to be sawn is firmly secured in place.
- Apply only a gentle pressure to the tool and do not exert side pressure on the saw blade.
- Avoid overloading.

The attention of UK users is drawn to the "woodworking machines regulations 1974" and any subsequent amendments.

Ensure the machine is placed to satisfy your ergonomic conditions in terms of table height and stability. The machine site shall be chosen so that the operator has a good overview and enough free surrounding space around the machine that allows handling of the workpiece without any restrictions. To reduce effects of vibration make sure the environment temperature is not too cold, machine and accessory is well maintained and the workpiece size is suitable for this machine.

**Prior to operation:**

- Install the appropriate saw blade. Do not use excessively worn blades. The maximum rotation speed of the tool must not exceed that of the saw blade.
- Do not attempt to cut excessively small pieces.
- Allow the blade to cut freely. Do not force.
- Allow the motor to reach full speed before cutting.
- Make sure all locking knobs and clamp handles are tight.

**Switching on and off (fig. A1, R1 - R3)**

This machine has two independent switching systems. In mitre saw mode, the trigger switch (11) is used (fig. R1). In saw bench mode, the on/off switch (1) is used (fig. R2). Integrated in the switch box is a motor overload protector with manual reset. In case of a power shut-off, proceed as follows:

- Make sure the machine has been switched off.
- Press the reset button (142).

**Mitre saw mode (fig. R1)**

A hole (122) is provided in the trigger for insertion of a padlock to lock the switch.

- To run the tool, press the trigger switch (11).
- To stop the tool, release the switch.

**Saw bench mode (fig. R2 & R3)**

The on/off switch offers multiple advantages:

- no-volt release function: should the power be shut off for some reason, the switch has to be deliberately reactivated.

- extra safety: the hinged safety enclosure plate (123) can be locked by passing a padlock through the holes (124 & 125). The plate also serves as an "easy to locate" emergency stop button as pressure on the front of the plate will depress the stop button.

- To switch the machine on, press the green start button (126).
- To switch the machine off, press the red stop button (127).

**Locking the switches**

- In order to avoid unauthorised use of the machine, lock both switches using padlocks.

**Basic saw cuts**

**Sawing in mitre saw mode**

It is dangerous to operate without guarding. Guards must be in position when sawing.

- Make sure that the under-table guard does not become clogged with sawdust.
- Always clamp the workpiece when cutting non-ferrous metals.

**General handling**

- In the mitre saw mode, the sawhead is automatically locked in the upper "park"-position.
- Squeezing the guard release lever will unlock the sawhead. Moving the sawhead down retracts the movable lower guard.
- Never seek to prevent the lower guard returning to its park position when the cut is completed.
- The minimum length of offcut material is 10 mm.
- When cutting short material (min. 190 mm to the left or the right of the blade), the use of the optional material clamp is recommended.
- When cutting UPVC sections, a supporting piece made out of timber with a complementary profile should be placed beneath the material being cut to provide the correct level of support.

**Vertical straight cross cut (fig. S1)**

- Loosen the mitre knob (79) and depress the mitre latch (80).
- Engage the mitre latch at the 0° position and tighten the mitre knob.
- Place the wood to be cut against the fence (7).
- Take hold of the operation handle (10) and press in the guard release lever (9).
- Press the trigger switch (11) to start the motor.
- Depress the head to allow the blade to cut through timber and enter the saw kerf (81).
- After completing the cut, release the switch and wait for the saw blade to come to a complete stillstand before returning the head to its upper rest position.

**Vertical mitre cross-cut (fig. S2)**

- Loosen the mitre knob (79) and depress the mitre latch (80). Move the rotating table left or right to the required angle.
- The mitre latch will automatically locate at 15°, 22.5°, 35.3° and 45° both left and right. If any intermediate angle is required hold the head firmly and lock by tightening the mitre knob.
- Always ensure that the mitre knob is locked tightly before cutting.
- Proceed as for a vertical straight cross-cut.



**WARNING:** When mitring the end of a piece of wood with a small off-cut, position the wood to ensure that the off-cut is to the side of the blade with the greater angle to the fence:

left mitre,                      off-cut to the right  
right mitre,                     off-cut to the left.

**Bevel cross-cut (fig. A2, S3)**

Bevel angles can be set from 48° left to 2° right and can be cut with the rotating table set between zero and a maximum of 45° mitre position left or right.

- Loosen the fence clamping knob (91) and slide the upper part of the side fence to the left as far as it will go.
- Loosen the bevel clamp knob (17) and set the bevel as desired.
- Tighten the bevel clamp knob firmly.
- Proceed as for a vertical straight cross-cut.

### Compound mitre (fig T1 - T4)

A compound mitre is a cut made using a mitre angle (fig. T1) and a bevel angle (fig. T2) at the same time. This is the type of cut used to make frames or boxes with slanting sides like the one shown in fig. T3.



**WARNING:** If the cutting angle varies from cut to cut, check that the bevel clamp knob and the mitre lock knob are securely tightened. These knobs must be tightened after making any changes in bevel or mitre.

- The chart shown below will assist you in selecting the proper bevel and mitre settings for common compound mitre cuts. To use the chart, select the desired angle "A" (fig. T4) of your project and locate that angle on the appropriate arc in the chart. From that point follow the chart straight down to find the correct bevel angle and straight across to find the correct mitre angle.
- Set your saw to the prescribed angles and make a few trial cuts.
- Practice fitting the cut pieces together.
- Example: To make a 4 sided box with 25° exterior angles (angle "A") (fig. T4), use the upper right arc. Find 25° on the arc scale. Follow the horizontal intersecting line to either side to get the mitre angle setting on the saw (23°). Likewise follow the vertical intersecting line to the top or bottom to get the bevel angle setting on the saw (40°). Always try cuts on a few scrap pieces of wood to verify the settings on the saw.

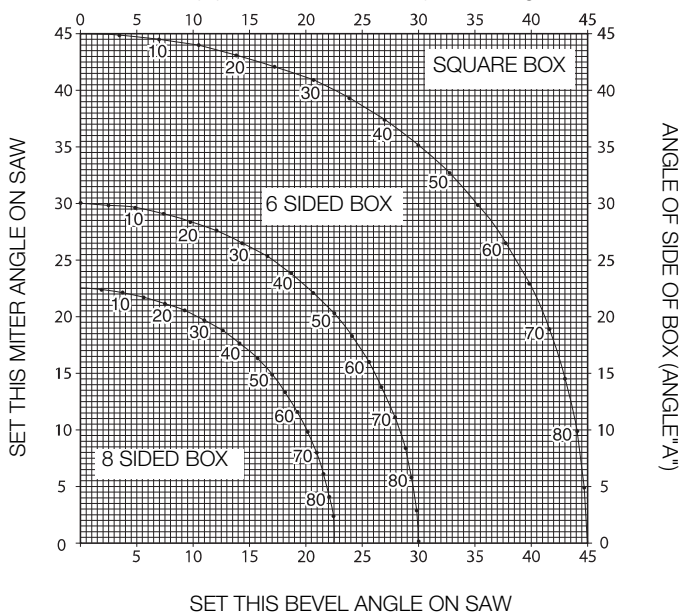

### Cutting base mouldings

The cutting of base moulding is performed at a 45° bevel angle.

- Always make a dry run without power before making any cuts.
- All cuts are made with the back of the moulding laying flat on the saw.

### Inside corner

- Left side
  - Position the moulding with top of the moulding against the fence.
  - Save the left side of the cut.
- Right side
  - Position the moulding with the bottom of the moulding against the fence.
  - Save the left side of the cut.

### Outside corner

- Left side
  - Position the moulding with the bottom of the moulding against the fence.
  - Save the right side of the cut.
- Right side
  - Position the moulding with top of the moulding against the fence.
  - Save the right side of the cut.

### Cutting crown mouldings

The cutting of crown moulding is performed in a compound mitre. In order to achieve extreme accuracy, your saw has pre-set angle positions at 35.3° mitre and 30° bevel. These settings are for standard crown mouldings with 45° angles at the top and 45° angles at the bottom.

- Make test cuts using scrap material before doing the final cuts.
- All cuts are made in a left bevel and with the back of the moulding against the base.

### Inside corner

- Left side
  - Top of the moulding against the fence.
  - Mitre right.
  - Save the left side of the cut.
- Right side
  - Bottom of the moulding against the fence.
  - Mitre left.
  - Save the left side of the cut.

### Outside corner

- Left side
  - Bottom of the moulding against the fence.
  - Mitre left.
  - Save the right side of the cut.
- Right side
  - Top of the moulding against the fence.
  - Mitre right.
  - Save the right side of the cut.

### Sawing in the bench mode

- Always use the riving knife.
- Always ensure that the riving knife and blade guard are correctly aligned.
- Always ensure that the mitre saw is set and locked in 0° mitre.



**WARNING:** Do not cut metal in this mode.

### Ripping (fig. U1 & U3)

- Set the bevel angle to 0°.
- Adjust the saw blade height.
- Set the parallel fence to the required distance.
- Hold the workpiece flat on the table and against the fence. Keep the workpiece approx. 25 mm away from the saw blade.
- Keep both hands away from the path of the saw blade.
- Switch the machine on and allow the saw blade to reach full speed.
- Slowly feed the workpiece underneath the upper blade guard, keeping it firmly pressed against the fence. Allow the teeth to cut, and do not force the workpiece through the saw blade. The saw blade speed should be kept constant.
- Remember to use the push stick (23) when close to the blade.

- After completing the cut, switch the machine off, allow the saw blade to stop and remove the workpiece.



**WARNING:** Never push or hold the free or cut-off side of the workpiece.

**WARNING:** Always use a push stick when ripping small workpieces.

#### Bevel cuts (fig. U2)

- Set the required bevel angle.
- Proceed as for ripping.

#### Cross-cutting (fig. V1)

- Set the bevel angle to 0°.
- Adjust the saw blade height.
- Set the mitre fence to 0°.
- Proceed as for ripping, only use the mitre fence to push the workpiece through the blade.

#### Bevel cross-cutting

- Set the required bevel angle.
- Proceed as for cross-cutting.

#### Mitre cuts (fig. V2)

- Set the mitre fence to the required angle.
- Proceed as for cross-cutting.

#### Optional attachments



**WARNING:** Prior to assembling any accessories always unplug the machine.

#### Dust extraction kit (fig. W1 & W2)



**WARNING!** This machine is provided with two dust extraction points for use in each mode.



**WARNING!** Whenever possible, connect a dust extraction device designed in accordance with the relevant regulations regarding dust emission.



**WARNING!** When sawing wood, connect a dust extraction device designed in accordance with the relevant regulations regarding dust emission.

Connect a dust collection device designed in accordance with the relevant regulations. The air velocity of externally connected systems shall be 20 m/s ± 2 m/s. Velocity to be measured in the connection tube at the point of connection, with the tool connected but not running. tion tube at the point of connection, with the tool connected but not running.

#### Connecting - mitre saw position (fig. W1)

- Connect the one end of the first hose to the dust extraction adaptor (13).
- Insert the other end of the hose into the middle inlet port of the manifold (128).
- Connect the one end of the other hose to the under-table guard (63).
- Insert the other end of the hose into the outer inlet port of the manifold.

#### Connecting - saw bench position (fig. W2)

- Proceed as for mitre saw position, only connect the hose from the under-table guard to the saw blade guard (21).

#### Mitre saw extra support/length stop (fig. A5)

The extra support and length stop can be mounted on the left-hand side or on the right-hand side, or with two sets on either side.

- Fit the items 31 - 39 onto the two guide rails (32 & 33).
- Use the inclinable support (34) for cross-cutting 210 mm wide boards (15 mm thick).

#### Roller support table (fig. A6)

The roller support table (40) is used to support long workpieces. In mitre saw mode, the roller support table can be mounted on the left-hand side or on the right-hand side, or with two sets on either side. In saw bench mode, it can also be mounted in front or at the rear of the saw table.

#### Side extension table (fig. A8)

The side extension table increases the distance from the rip fence to the blade to 600 mm or more, depending on the rod length fitted to the machine and the clamped position of the table. The side extension table must be used in conjunction with guide rails (32) (option). The adjustable table is equipped with an engraved scale along its front edge and mounted on a sturdy base which clamps to the guide rods.

- Fit the extension table to the right-hand side of the machine for continuity of the distance scale on both tables.

#### Sliding table (fig. A9)

This sliding table (43) allows for board sizes to the left of the blade up to 1200 x 900 mm.

The guide rods are mounted on a sturdy alloy extrusion which is quickly detachable from the machine and yet fully adjustable in all planes.

The fence incorporates a full length measuring tape for quick positioning of an adjustable stop and an adjustable support for narrow workpieces.

#### Transporting (fig. X)



**WARNING:** Always transport the machine in saw bench mode with the upper blade guard fitted.

The castor wheels provide an easier transport of the machine.

- Put the machine on the right base side.
- Fold the rear legs into the base
- Fold the front legs out of the base
- Turn the machine straight up.
- Lift the machine by the front legs up to the wheels are in contact with the floor.



**WARNING:** When carrying the machine, always seek assistance.

#### Maintenance

Your DEWALT power tool has been designed to operate over a long period of time with a minimum of maintenance. Continuous satisfactory operation depends upon proper tool care and regular cleaning.



**WARNING:** To reduce the risk of injury, turn unit off and disconnect machine from power source before installing and removing accessories, before adjusting or changing set-ups or when making repairs. Be sure the trigger switch is in the OFF position. An accidental start-up can cause injury.



#### Lubrication

The bearings of the motor are pre-lubricated and watertight.

- Slightly oil the rotating table bearing surface where it slides on the lip of the fixed table at regular intervals.
- Periodically lubricate the depth of cut screwthread.
- Clean the parts subject to accumulation of sawdust and chips periodically with a dry brush.

#### Cam adjustment (fig. Y1 - Y3)

To take out the clearance between the two tables, proceed as follows:

- Rotate the machine into saw bench mode.
- Remove the screws (138) and the retainer plate (139).



- Loosen the screw (140) of the adjustment cam (141).
- Rotate the adjustment cam using a pair of needle nose pliers.
- Hold the adjustment cam with the pliers and tighten the screw.
- Replace the retainer plate and tighten the screws.
- Rotate the machine into mitre saw mode. Check the force that is needed to mitre the saw. Repeat the above steps if the force needed is too high.



## Cleaning

Before use, carefully check the upper blade guard, movable lower blade guard as well as the dust extraction tube to determine that it will operate properly. Ensure that chips, dust or workpiece particle cannot lead to blockage of one of the functions.

In case of workpiece fragments jammed between saw blade and guards disconnect the machine from the power supply and follow the instructions given in section **Mounting the Saw Blade**. Remove the jammed parts and reassembling the saw blade.



**WARNING:** Blow dirt and dust out of the main housing with dry air as often as dirt is seen collecting in and around the air vents. Wear approved eye protection and approved dust mask when performing this procedure.



**WARNING:** Never use solvents or other harsh chemicals for cleaning the non-metallic parts of the tool. These chemicals may weaken the materials used in these parts. Use a cloth dampened only with water and mild soap. Never let any liquid get inside the tool; never immerse any part of the tool into a liquid.



**WARNING:** To reduce the risk of injury, regularly clean the table top.



**WARNING:** To reduce the risk of injury, regularly clean the dust collection system.

## Optional Accessories



**WARNING:** Since accessories, other than those offered by DEWALT, have not been tested with this product, use of such accessories with this tool could be hazardous. To reduce the risk of injury, only DEWALT, recommended accessories should be used with this product.



### LASER WARNING:

LASER RADIATION: DO NOT STARE INTO BEAM  
CLASS 2 PRODUCT  
MAXIMUM OUTPUT POWER  
 $P = < 1 \text{ mW}; \lambda_{\text{peak}} = 630 \text{ nm} - 680 \text{ nm}$   
IEC 60825-1: 2007

Consult your dealer for further information on the appropriate accessories.

## Protecting the Environment



Separate collection. This product must not be disposed of with normal household waste.



Should you find one day that your DEWALT product needs replacement, or if it is of no further use to you, do not dispose of it with household waste. Make this product available for separate collection.



Separate collection of used products and packaging allows materials to be recycled and used again. Re-use of recycled materials helps prevent environmental pollution and reduces the demand for raw materials.

Local regulations may provide for separate collection of electrical products from the household, at municipal waste sites or by the retailer when you purchase a new product.

DEWALT provides a facility for the collection and recycling of DEWALT products once they have reached the end of their working life. To take advantage of this service please return your product to any authorised repair agent who will collect them on our behalf.

You can check the location of your nearest authorised repair agent by contacting your local DEWALT office at the address indicated in this manual. Alternatively, a list of authorised DEWALT repair agents and full details of our after-sales service and contacts are available on the Internet at: [www.2helpU.com](http://www.2helpU.com).

## GUARANTEE

DEWALT is confident of the quality of its products and offers an outstanding guarantee for professional users of the product. This guarantee statement is in addition to and in no way prejudices your contractual rights as a professional user or your statutory rights as a private non-professional user. The guarantee is valid within the territories of the Member States of the European Union and the European Free Trade Area.

### • 30 DAY NO RISK SATISFACTION GUARANTEE •

If you are not completely satisfied with the performance of your DEWALT tool, simply return it within 30 days, complete with all original components, as purchased, to the point of purchase, for a full refund or exchange. The product must have been subject to fair wear and tear and proof of purchase must be produced.

### • ONE YEAR FREE SERVICE CONTRACT •

If you need maintenance or service for your DEWALT tool, in the 12 months following purchase, it will be undertaken free of charge at an authorised DEWALT repair agent. Proof of purchase must be produced. Includes labour. Excludes accessories and spare parts unless failed under warranty.

### • ONE YEAR FULL WARRANTY •

If your DEWALT product becomes defective due to faulty materials or workmanship within 12 months from the date of purchase, DEWALT guarantees to replace all defective parts free of charge or – at our discretion – replace the unit free of charge provided that:

- The product has not been misused;
- The product has been subject to fair wear and tear;
- Repairs have not been attempted by unauthorised persons;
- Proof of purchase is produced;
- The product is returned complete with all original components.

If you wish to make a claim, contact your seller or check the location of your nearest authorised DEWALT repair agent in the DEWALT catalogue or contact your DEWALT office at the address indicated in this manual. A list of authorised DEWALT repair agents and full details of our after-sales service is available on the Internet at: [www.2helpU.com](http://www.2helpU.com).

<b>Belgique et Luxembourg België en Luxemburg</b>	Black & Decker - DEWALT Nieuwlandlaan 7, IZ Aarschot B156 B-3200 Aarschot	Tel: +32 (0)015 - 15 47 9211 Fax: +32 (0)015 - 15 47 9210 www.dewalt.be
<b>Danmark</b>	DEWALT Sluseholmen 2-4 2450 København SV	Tlf: 70201511 Fax: 70224910 www.dewalt.dk
<b>Deutschland</b>	DEWALT Richard-Klinger-Straße 65510 Idstein	Tel: 06126-21-1 Fax: 06126-21-2770 www.dewalt.de
<b>Ελλάς</b>	Black & Decker (Hellas) S.A. Στράβωνος 7 & Βουλιαγμένης 159 Γλυφάδα 16674, Αθήνα	Τηλ: (01) 8981-616 Φαξ: (01) 8983-570 Service: (01) 8982-630
<b>España</b>	DEWALT Parque de Negocios "Mas Blau" Edificio Muntadas, c/Bergadá, 1, Of. A6 08820 El Prat de Llobregat (Barcelona)	Tel: 934 797 400 Fax: 934 797 439 www.dewalt.es
<b>France</b>	DEWALT 5, allée des hêtres BP 30084, 69579 Limonest Cedex	Tel: 04 72 20 39 20 Fax: 04 72 20 39 00 www.dewalt.fr
<b>Schweiz Suisse Svizzera</b>	DEWALT In der Luberzen 40 8902 Urdorf	Tel: 01 - 730 67 47 Fax: 01 - 730 70 67 www.dewalt.ch
<b>Ireland</b>	DEWALT Calpe House Rock Hill Black Rock, Co. Dublin	Tel: 00353-2781800 Fax: 00353-2781811 www.dewalt.ie
<b>Italia</b>	DEWALT Viale Elvezia 2 20052 Monza (Mi)	Tel: 800-014353 Fax: 039-2387592 www.dewalt.it
<b>Nederlands</b>	Black & Decker - DEWALT Joulehof 12 4600 AB Bergen Op Zoom	Tel: 0164 283000 Fax: 0164 283100 www.dewalt.nl
<b>Norge</b>	DEWALT Postboks 4814, Nydalen 0422 Oslo	Tel: 22 90 99 00 Fax: 22 90 99 01 www.dewalt.no
<b>Österreich</b>	DEWALT Werkzeugevertriebs GmbH Erlaaerstraße 165, Postfach 320,1231 Wien	Tel: 01 - 66116 - 0 Fax: 01 - 66116 - 14 www.dewalt.at
<b>Portugal</b>	DEWALT Rua Egas Moniz 173 João do Estoril, 2766-651 Estoril	Tel: 214 66 75 00 Fax: 214 66 75 75 www.dewalt.pt
<b>Suomi</b>	DEWALT Oy Tekniikantie 12 02150 Espoo, Finland	Puh: 010 400 430 Faksi: 0800 411 340 www.dewalt.fi
	DEWALT Oy Teknikvägen 12 02150 Esbo, Finland	Tel: 010 400 430 Fax: 0800 411 340 www.dewalt.fi
<b>Sverige</b>	DEWALT Box 94 431 22 Mölndal	Tel: 031 68 61 00 Fax: 031 68 60 08 www.dewalt.se
<b>Türkiye</b>	KALE Hırdavat ve Makina A.Ş. Defterdar Mah. Savaklar Cad. No:15 Edirnekapı / Eyüp / İSTANBUL 34050 TÜRKİYE	Tel: 0212 533 52 55 Faks: 0212 533 10 05 www.dewalt.com.tr
<b>United Kingdom</b>	DEWALT 210 Bath Road Slough, Berks SL1 3YD	Tel: 01753-56 70 55 Fax: 01753-57 21 12 www.dewalt.co.uk